

2019



**LÍNEA
COMERCIAL
ARQUITECTÓNICA**

*P*anorama®

Somos una empresa 100% mexicana, líder en la industria del aluminio con 70 años en el mercado. Nuestros procesos están alineados de manera vertical desde la fundición, extrusión y acabados, realizados con los más estrictos estándares de calidad.

Nuestros diseños innovadores, atención y servicio nos ha convertido como la mejor opción en el mercado de la construcción.

Presentamos la nueva edición del catálogo **Panorama 2019**, línea exclusiva de Cuprum dirigida a la vivienda de interés social y media, cumpliendo con las necesidades básicas para la construcción arquitectónica. Podrás encontrar desde acabados y perfiles para el armado de sistemas: fijos, corredizos y batientes, además de cancel de baño, pasamanos, fachadas arquitectónicas, entre otros.

El propósito de Cuprum es continuar desarrollando a los Profesionales del Aluminio para cumplir con las expectativas de nuestros clientes

Alumineros hay muchos... Profesionales del Aluminio solo en Cuprum.



www.cuprum.com

Índice

Fijos

Fijo de 1.500" x 1.084"	4
Fijo Serie AB	5
Fijo de 2.000" x 1.250"	6
Fijo de 3.000" x 1.750"	7
Fijo de 3.000" x 1.250"	9
Fijo de 3.000" x 1.250" Doble Vidrio	10
Fijo de 4.000" x 1.750"	11

Corredizas

Ventana Económica de 1.500" C-Light	13
Ventana y Puerta Corrediza 2.000" x 1.250"	14
Ventana y Puerta Corrediza 3.000" x 1.250"	16
Mosquiteros y Adaptadores	19
Ventana Guillotina California 1.670"	20
Puerta Corrediza California 3.625"	21

Ventanas

Ventana Batiente Serie AB	22
Ventana de Proyección 2.000"	23
Ventana Sifón 3.000"	24

Puertas

Puerta Batiente de 1.000" Económica	25
Puerta Batiente Serie AB	26
Puerta Batiente de 1.750" Comercial	28

Cancel de Baño

Cancel de Baño de Lujo y Semi Lujo	30
Cancel de Baño Ligero	31
Cancel de Baño Varios	32

Aparadores y Vitrinas

Recubrimientos	33
-----------------------	----

Duela Cenefa	35
---------------------	----

Sardinell	36
------------------	----

Zoclo y Repizón	37
------------------------	----

Pasamanos	39
------------------	----

Celosías Louver	40
------------------------	----

Fachada Arquitectónica	43
-------------------------------	----

Std. Arquitectónico	47
----------------------------	----

Índice General	49
-----------------------	----

Pintura electrostática

- 100 - Blanco
- 101 - Hueso
- 102 - Beige
- 103 - Bronce
- 108 - Champagne
- 184 - Chocolate
- 737 - Gris Europa

Anodizados

- 005 - Champagne Brillante
- 010 - Natural Brillante
- 011 - Natural Mate
- 040 - Champagne Mate
- 084 - Bronce oscuro

Acabados Madera

- 601 - Caoba
- 603 - Nogal Texturizado

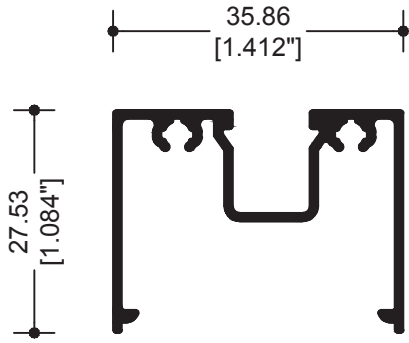

39073
BOLSA

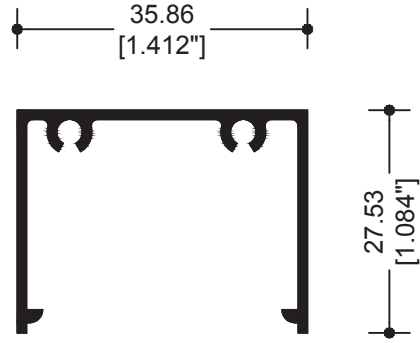

29076
BOLSA LISA

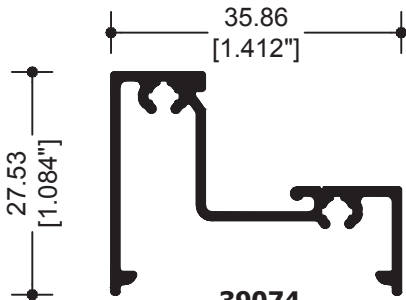

39074
ESCALONADO

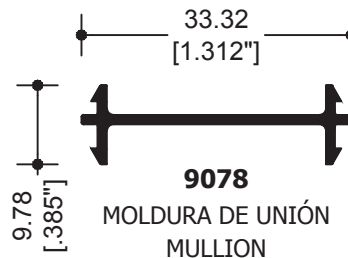

9078
MOLDURA DE UNIÓN
MULLION
PRODUCCIÓN
SIN ACABADO

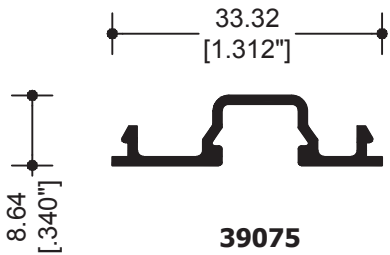

39075
TAPA BOLSA

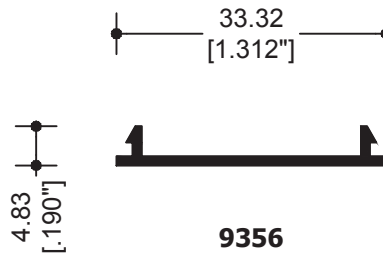

9356
TAPA LISA

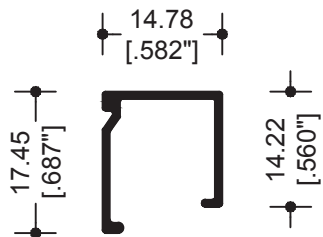

36370
JUNQUILLO

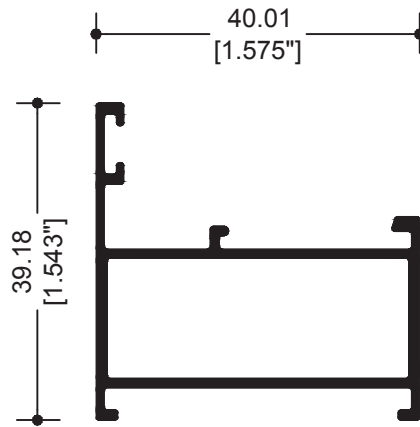

69877
MARCO
VENTANA

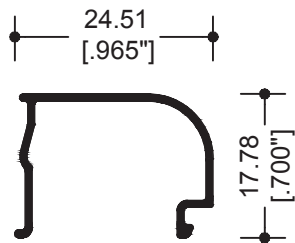

69891
JUNQUILLO
CONCAVO
SENCILLO

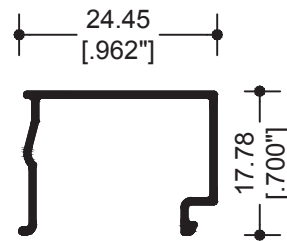

69890
JUNQUILLO
CUADRADO
SENCILLO

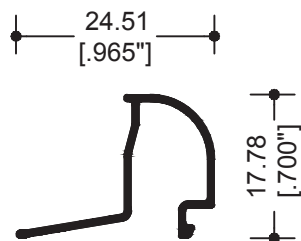

69887
JUNQUILLO
CONCAVO
DOBLE

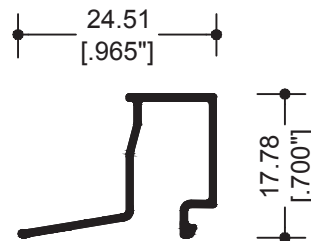

69888
JUNQUILLO
CUADRADO
DOBLE

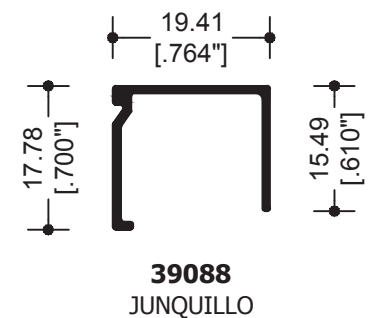
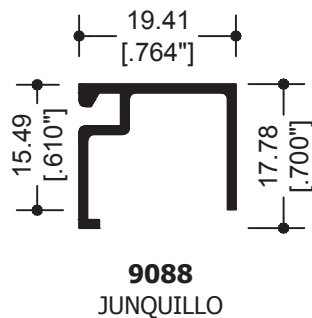
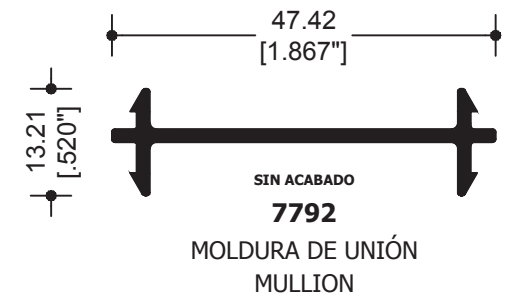
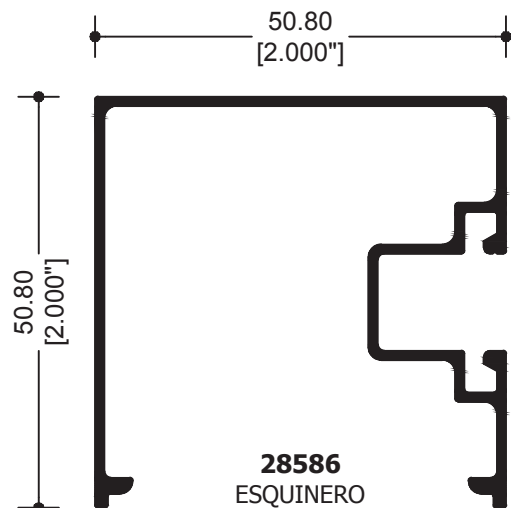
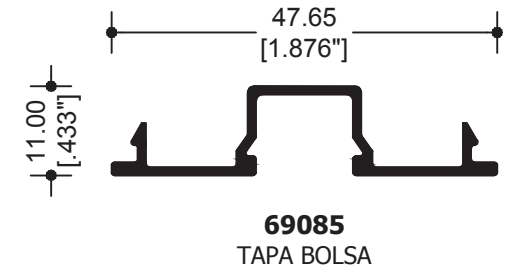
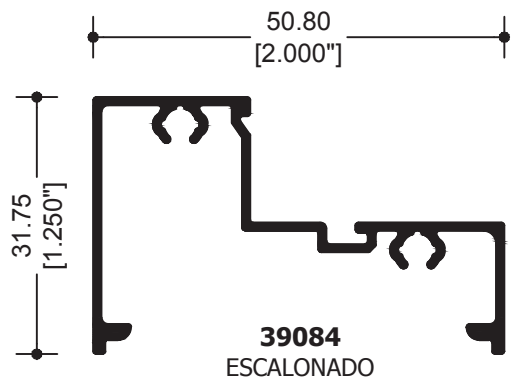
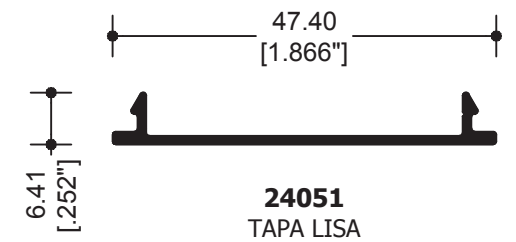
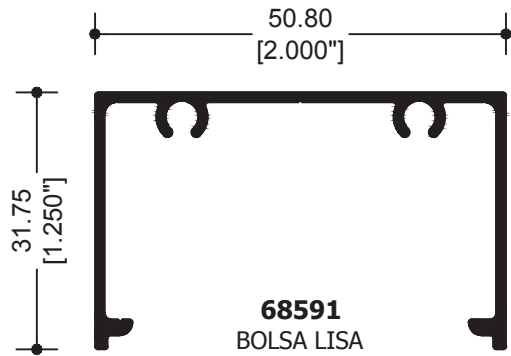
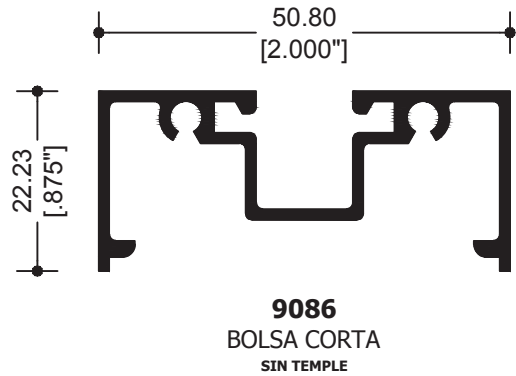
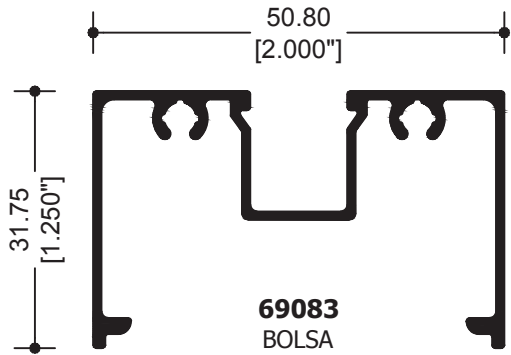

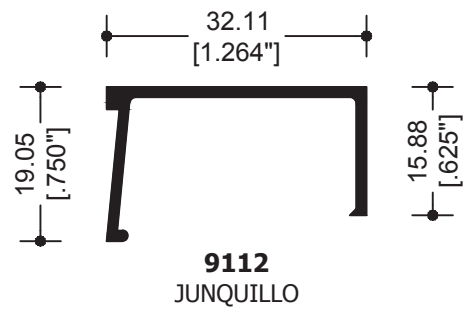
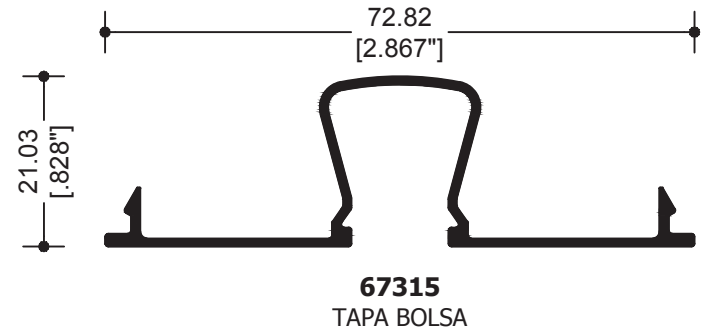
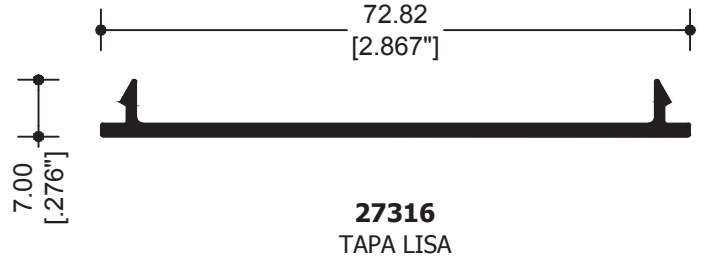
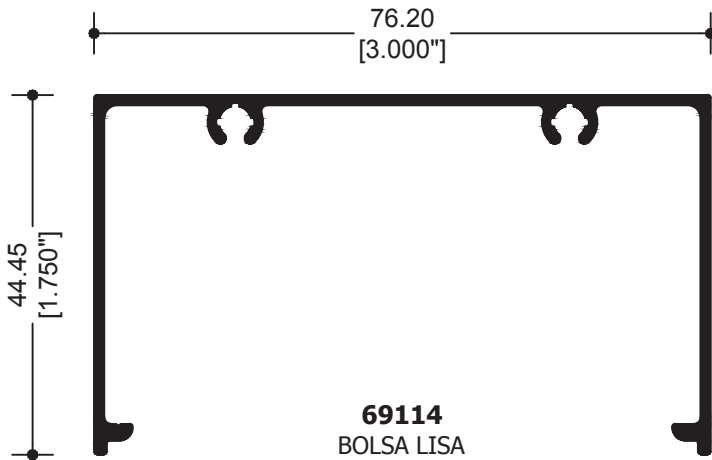
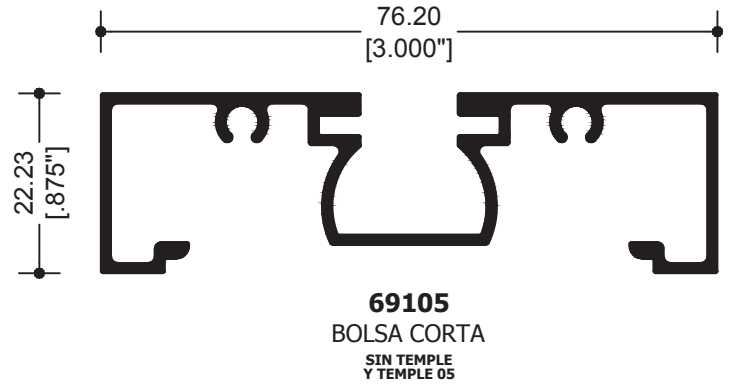
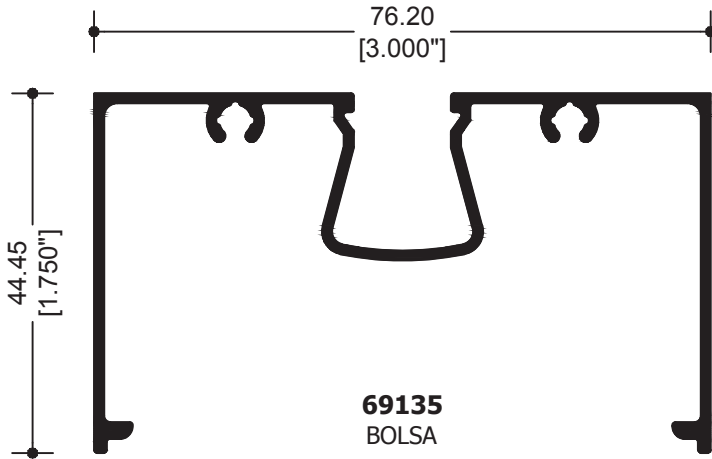

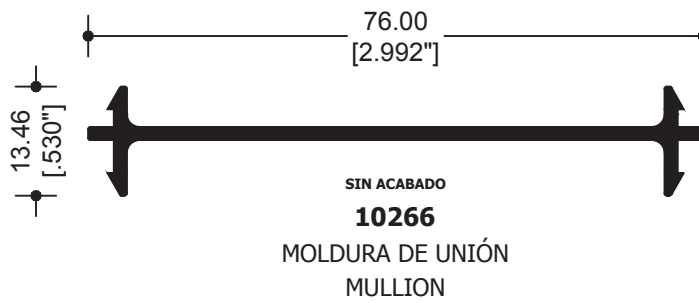
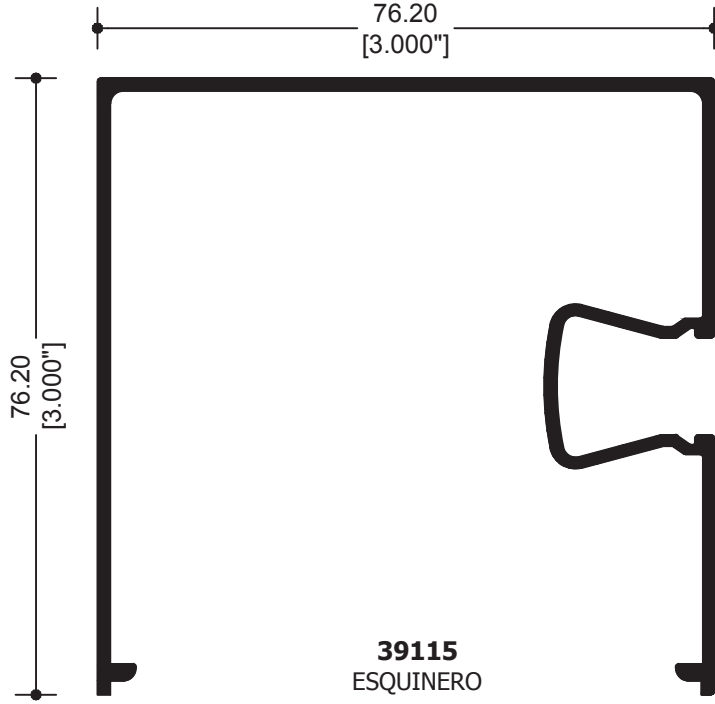

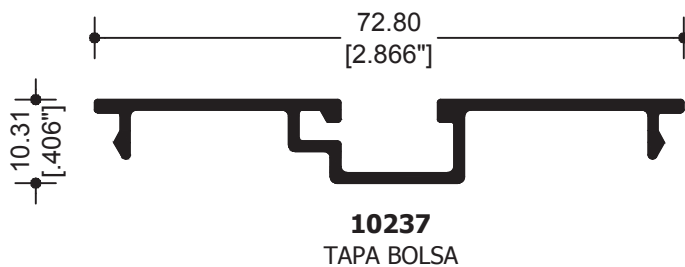
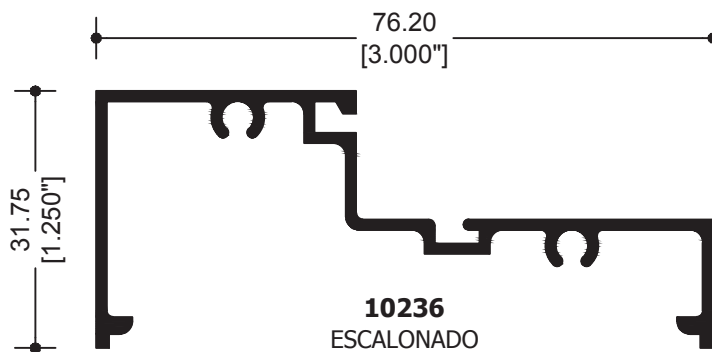
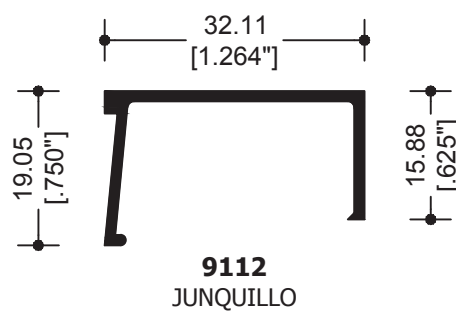
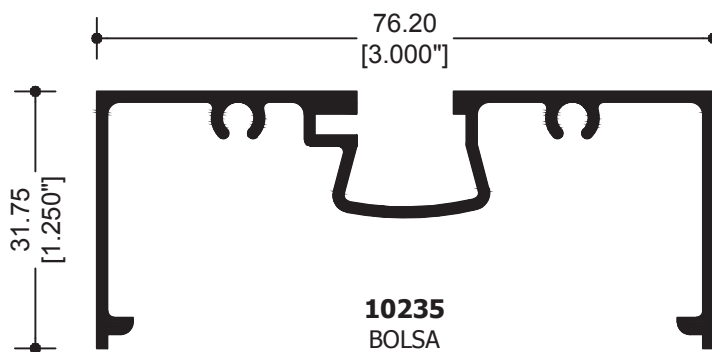

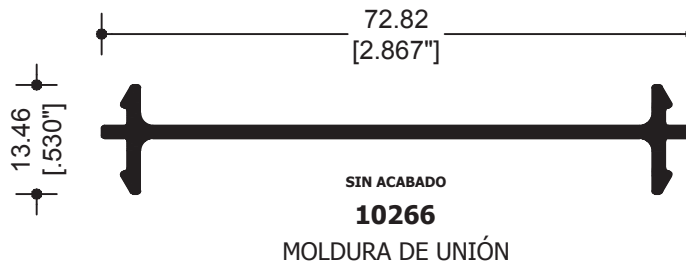
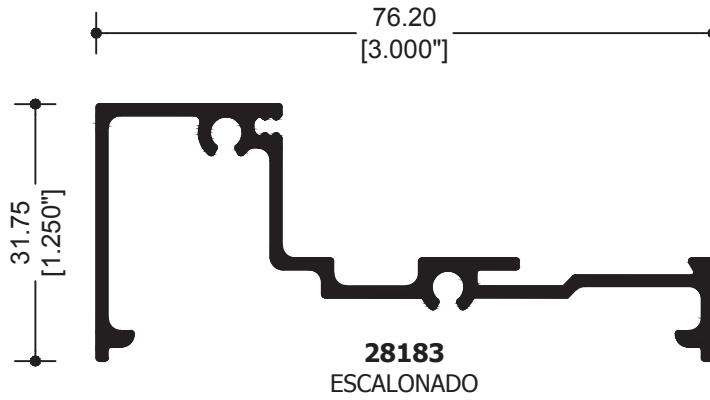
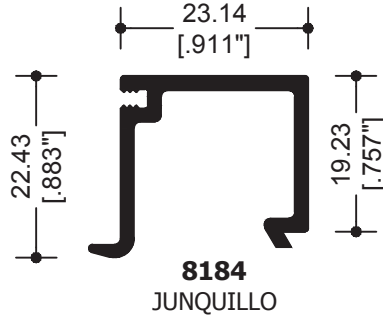
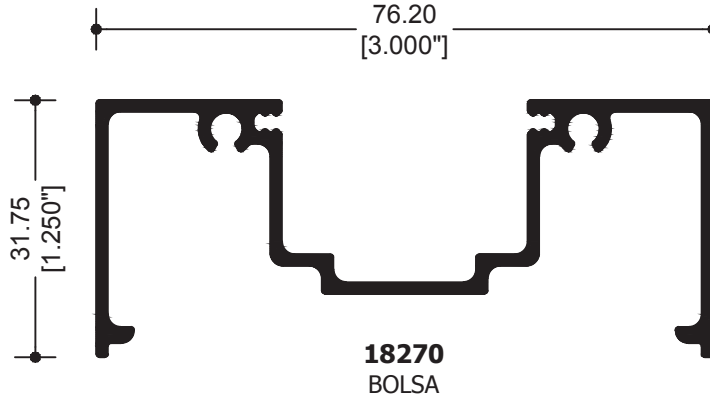

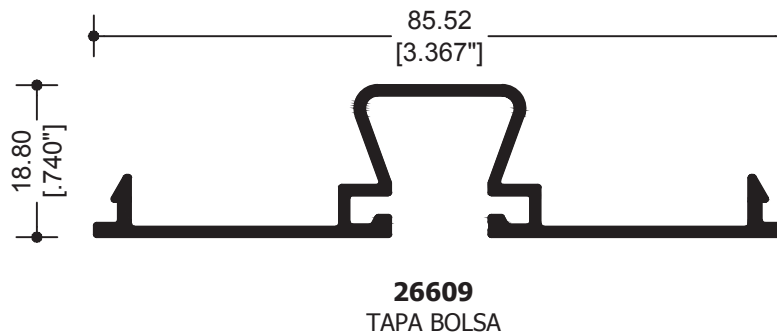
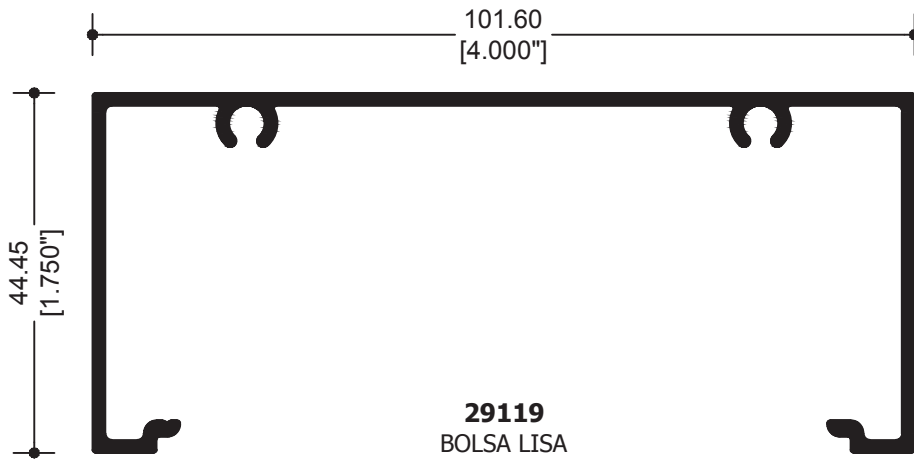
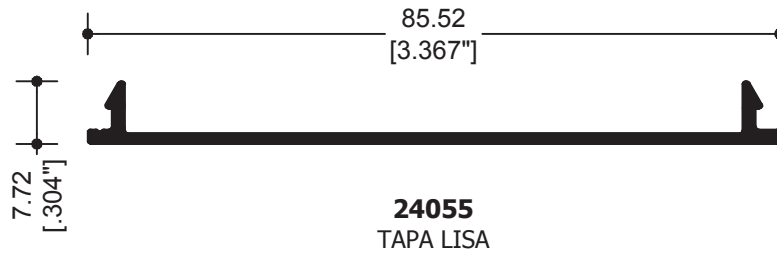
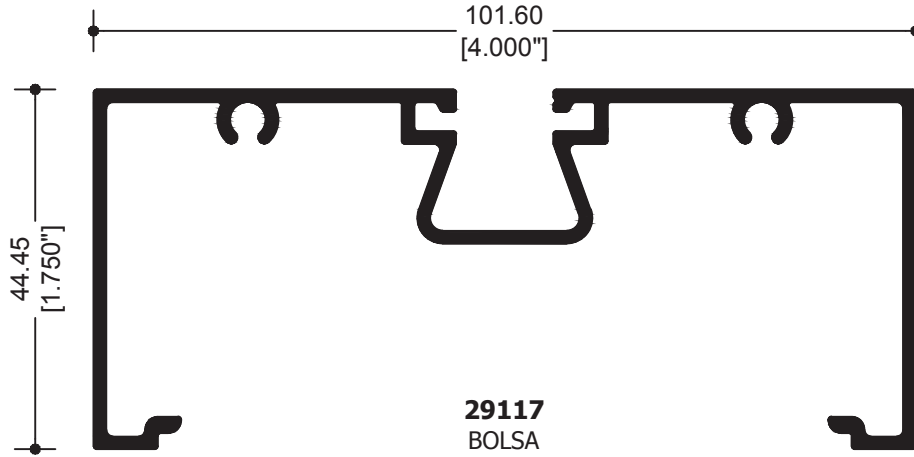

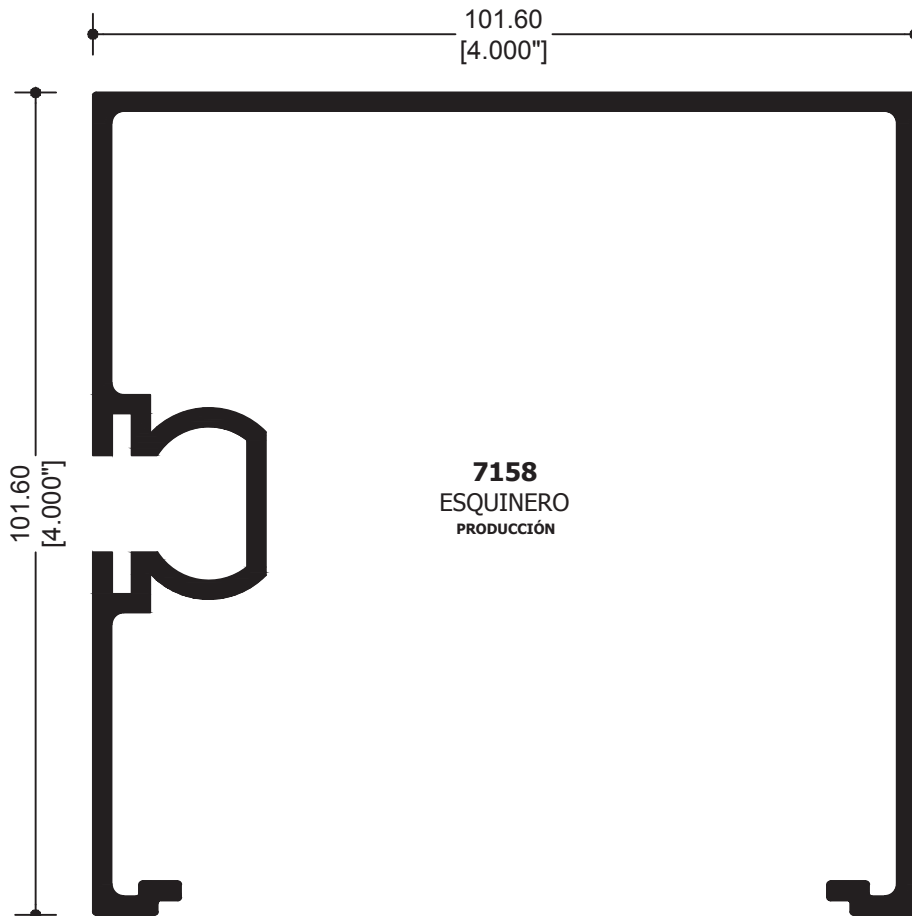
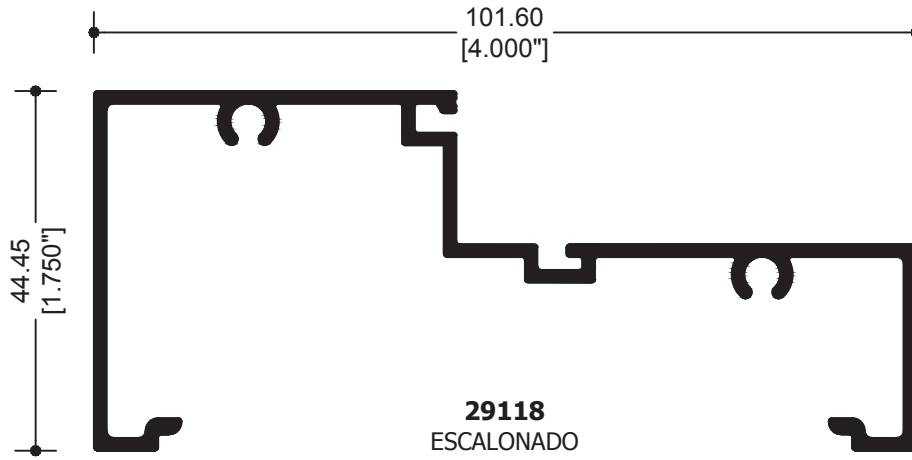
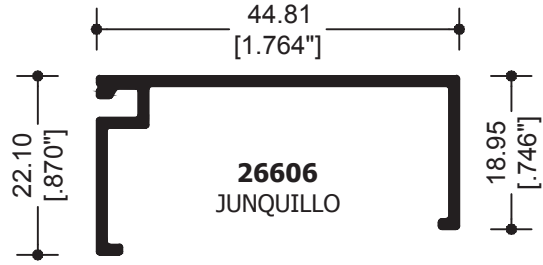

C-LIGHT IV

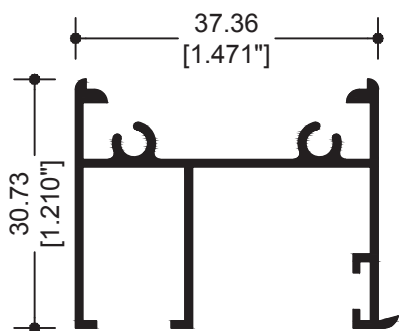

11835
JAMBA Y CABEZAL

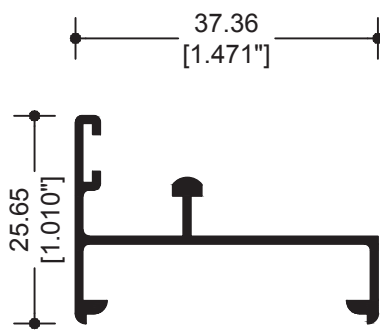

11838
RIEL

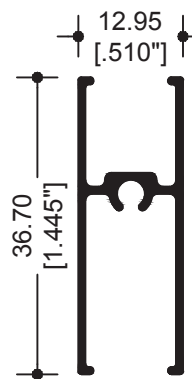

11837
CABEZAL Y ZOCLO

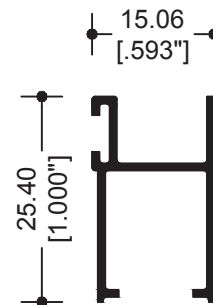

11836
CERCO

C-LIGHT V

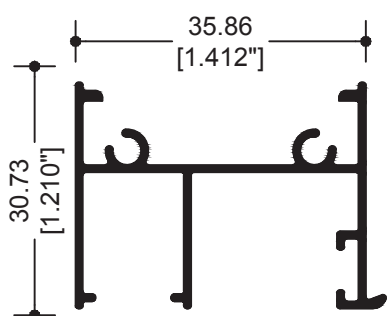

15309
JAMBA Y CABEZAL

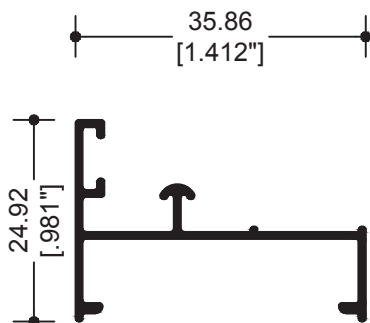

15310
RIEL

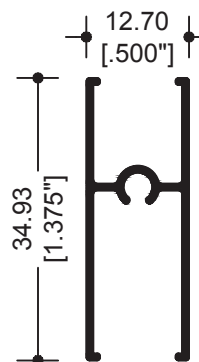

15311
CABEZAL Y ZOCLO

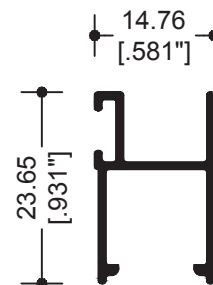

15312
CERCO

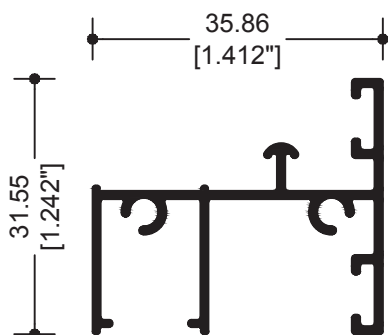

63862
INTERMEDIO
PRODUCCIÓN

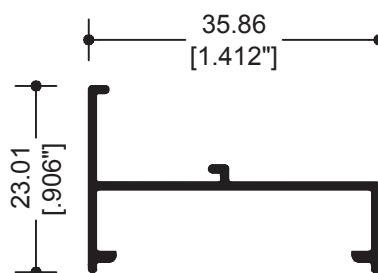

15313
ESCALONADO
PRODUCCIÓN

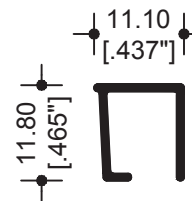

15314
JUNQUILLO
PRODUCCIÓN

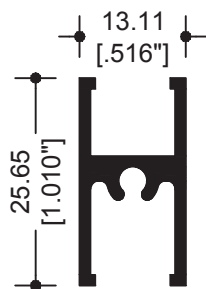

11203
INTERMEDIO PARA CUADRÍCULA

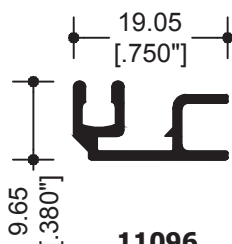

11096
MOSQUITERO

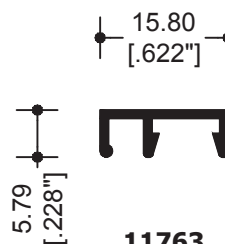

11763
MOSQUITERO

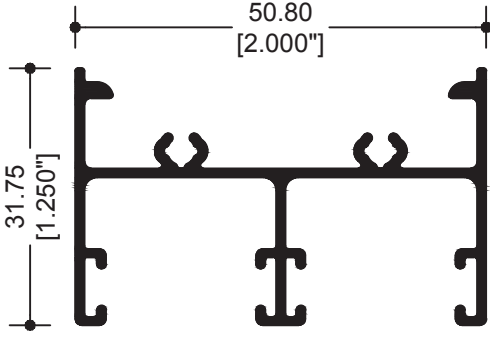

67518
CABEZAL Y JAMBA

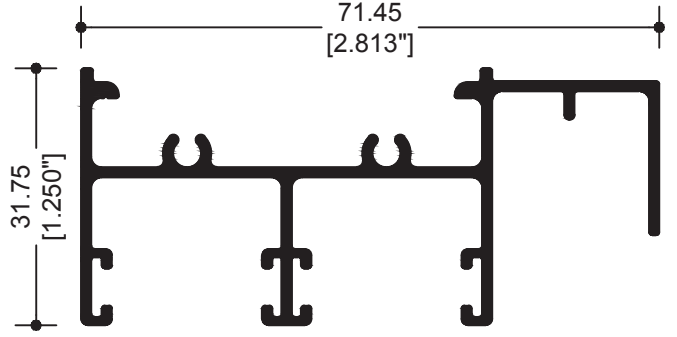

27819
CABEZAL MOS. CORREDIZO

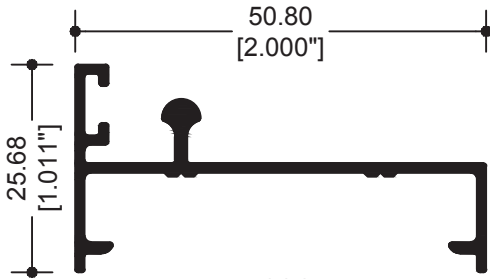

14286
RIEL

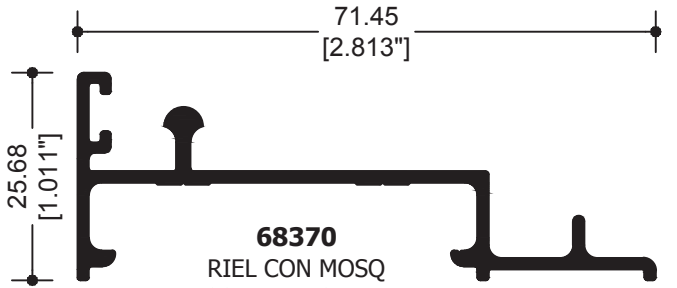

68370
RIEL CON MOSQ
CORREDIZO EXT.

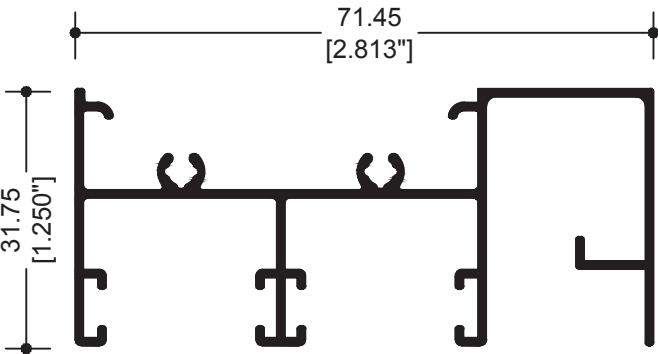

67819
CABEZAL MOSQUITERO COLGANTE

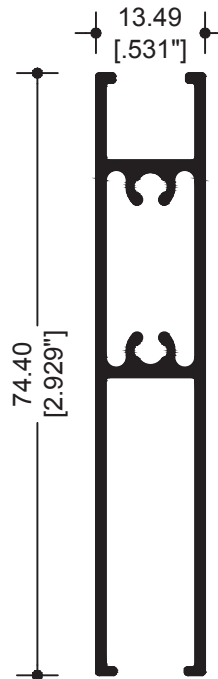

37825
ZOCLO PUERTA

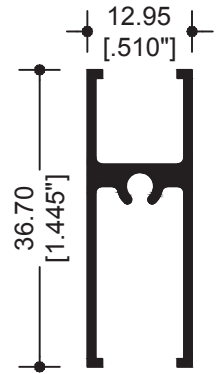

11044
CABEZAL Y ZOCLO

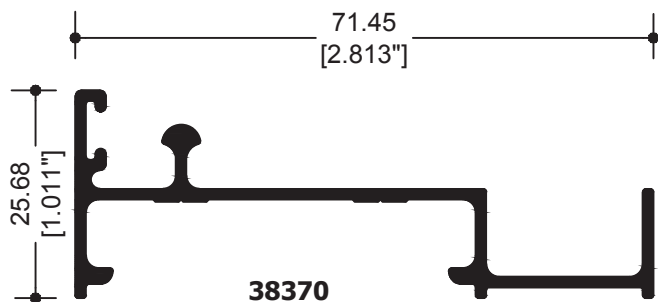

38370
RIEL CON MOSQ. EXT

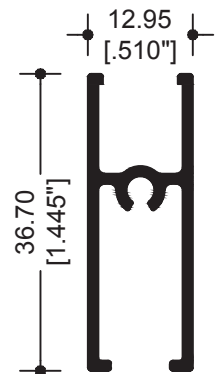

9956
CABEZAL Y ZOCLO

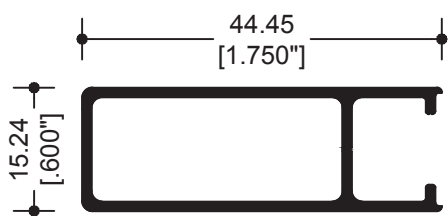

67821
CERCO PUERTA

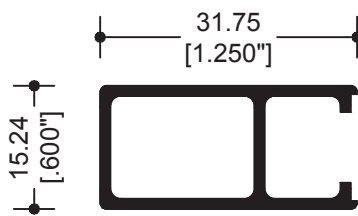

8320
CERCO VENTANA

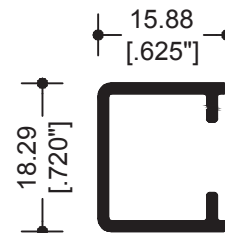

27525
CERCO FIJO ECONÓMICO

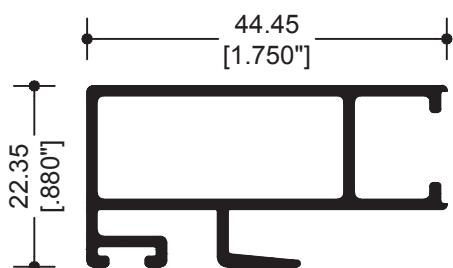

69955
TRASLAPE PUERTA

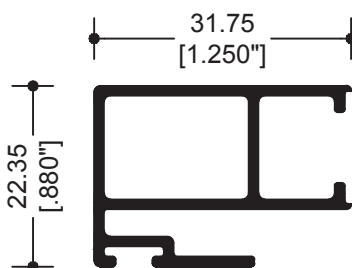

39954
TRASLAPE VENTANA

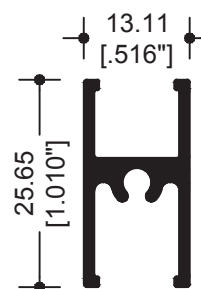

11203
INTERMEDIO PARA
CUADRÍCULA

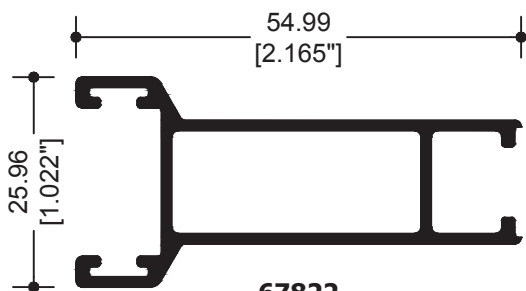

67822
CERCO OXXO PUERTA

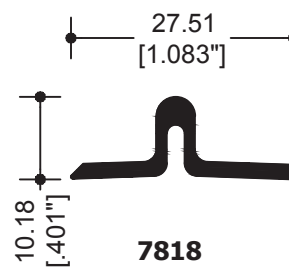

7818
ADAPTADOR XX

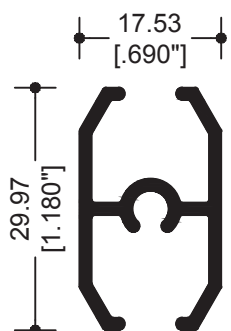

63728
PARA CUADRÍCULA
RECERCADO 2"

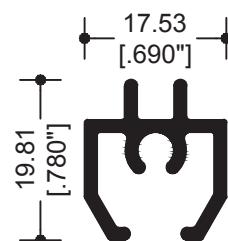

63727
BARROTILLO 2"

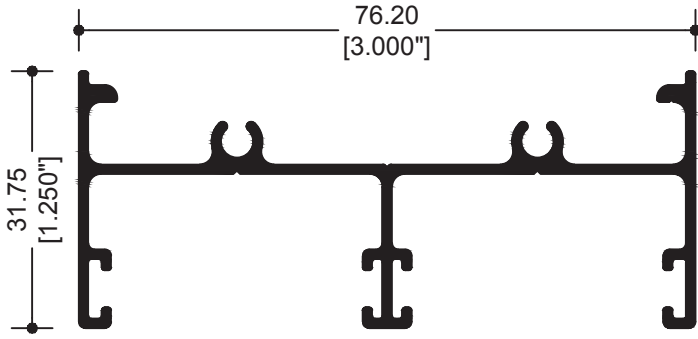

67826
CABEZAL Y JAMBA

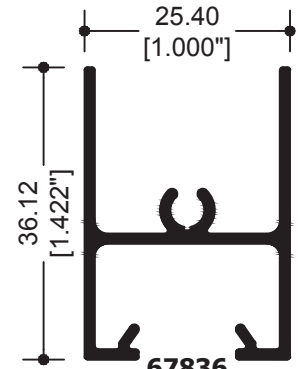

67836
CABEZAL VENTANA

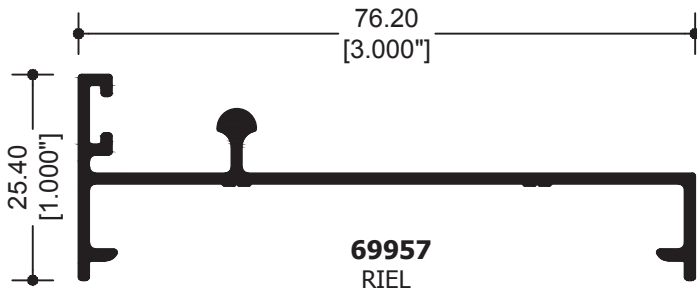

69957
RIEL

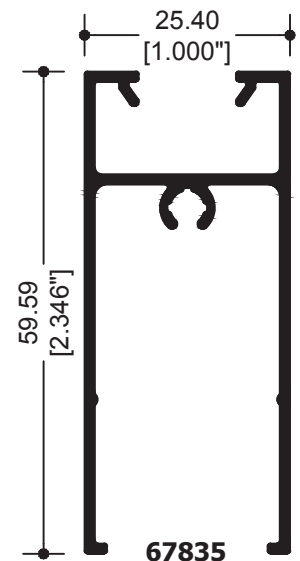

67835
ZOCLO VENTANA

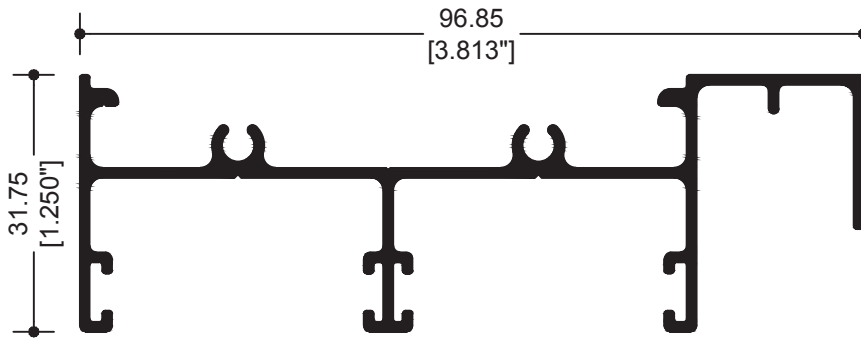

27862-77862
CABEZAL MOS. CORREDIZO

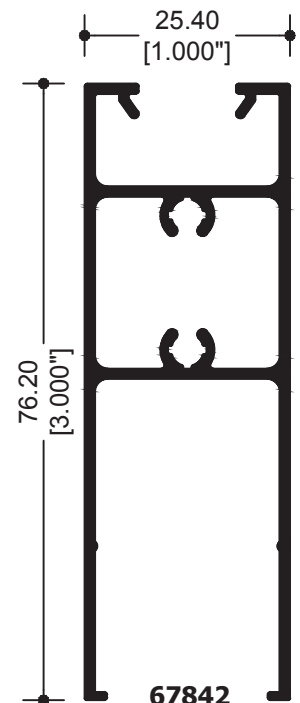

67842
ZOCLO PUERTA

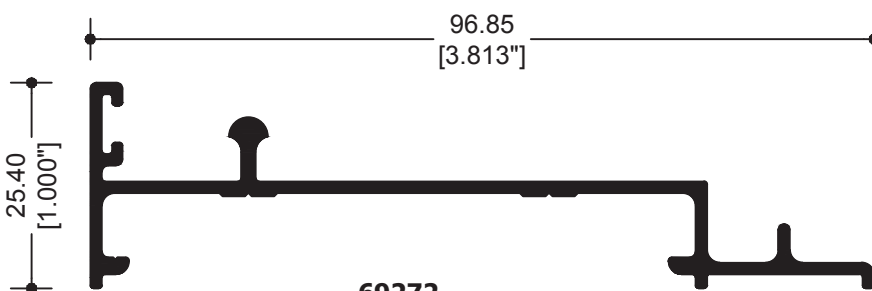

69272
RIEL PARA MOS. EXT. CORREDIZO

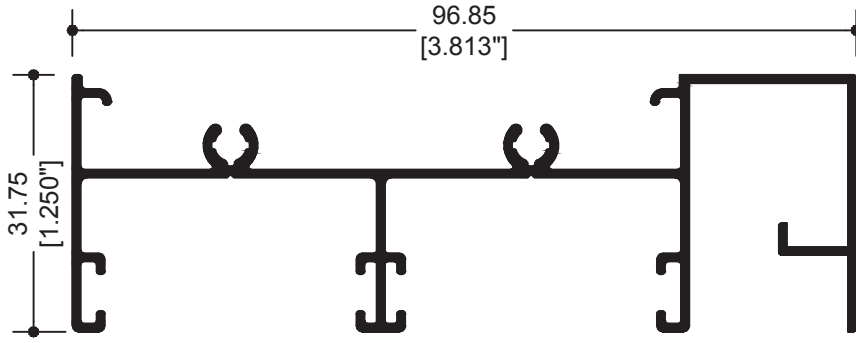

67862
CABEZAL MOSQUITERO COLGANTE

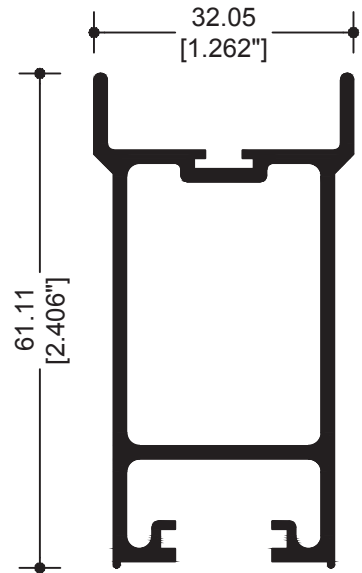

67850
CERCO OXXO

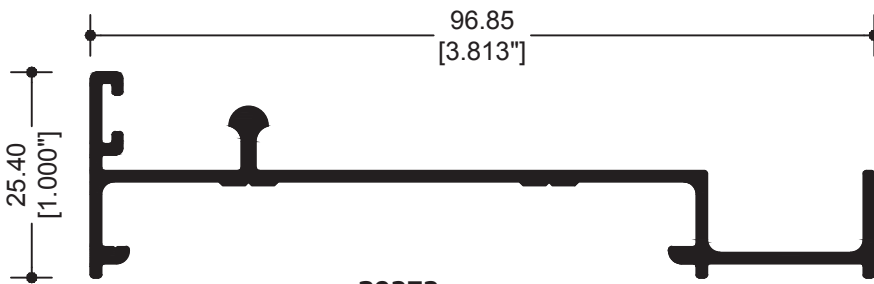

39272
RIEL PARA MOS. EXT. CORREDIZO

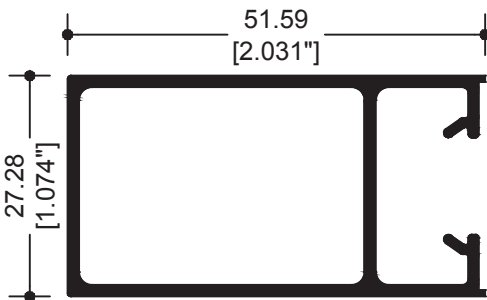

67847
CERCO CHAPA PUERTA

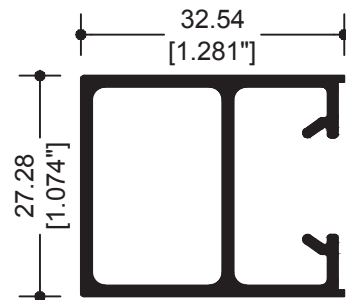

67843
CERCO VENTANA

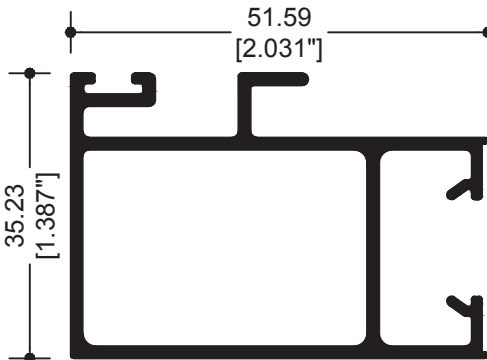

67848
TRASLAPE PUERTA

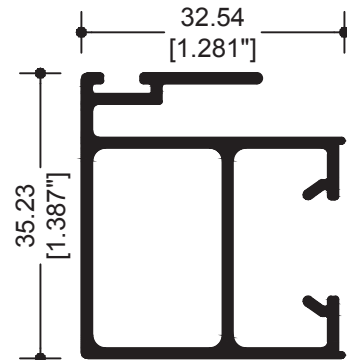

67844
CERCO TRASLAPE VENTANA

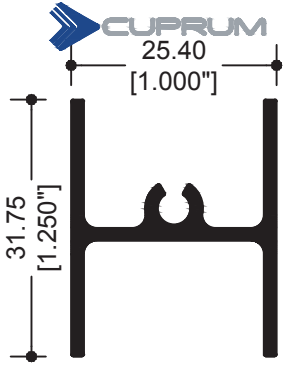

9958
CABEZAL DUO VENT

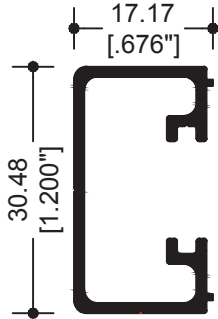

28681
ADAPTADOR FIJO

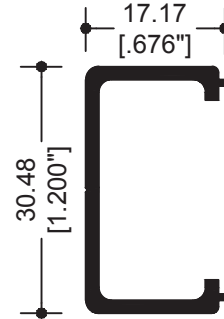

9965
CERCO FIJO

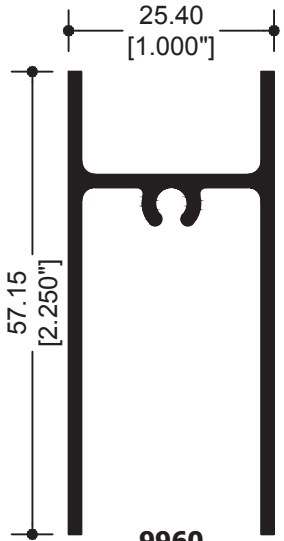

9960
ZOCLO VENTANA
VIDRIO DOBLE

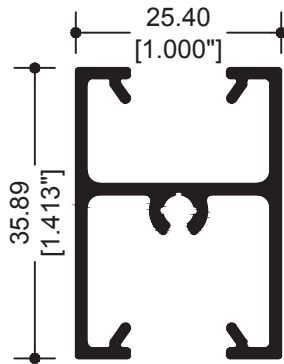

69082
INTERMEDIO

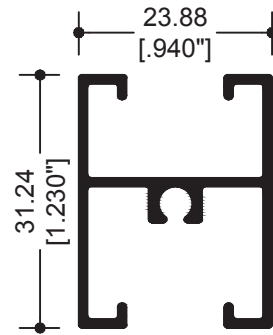

69768
INTERMEDIO

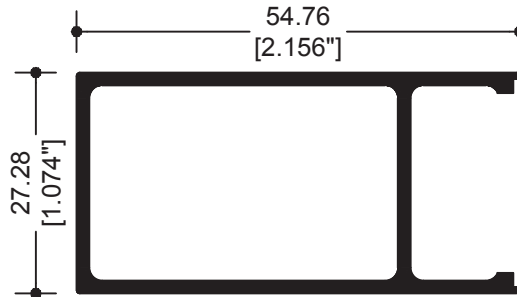

9964
CERCO PUERTA DOBLE VIDRIO

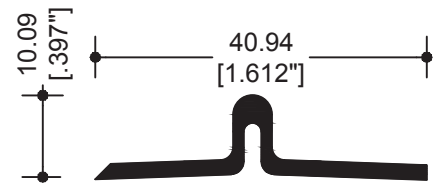

7828
ADAPTADOR XX

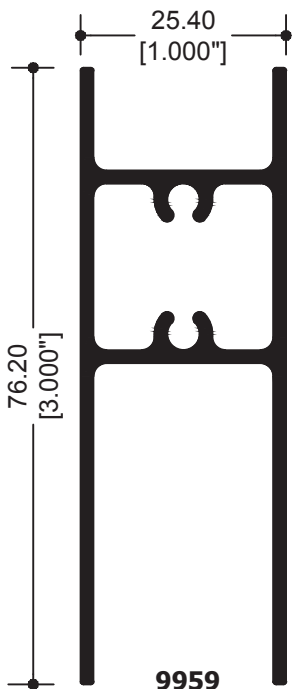

9959
ZOCLO PUERTA
VIDRIO DOBLE

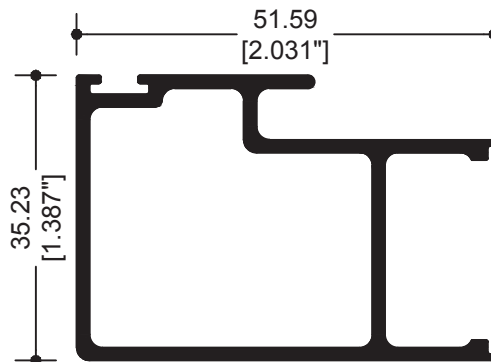

9963
TRASLAPE PUERTA DOBLE VIDRIO

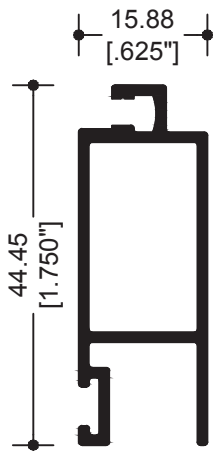

66534
CERCO MOSQUITERO

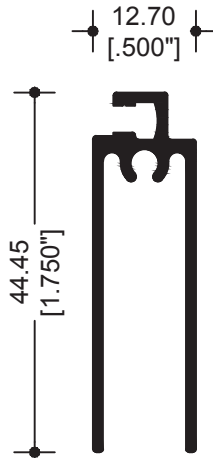

66533
CABEZAL Y ZOCLO
MOSQUITERO

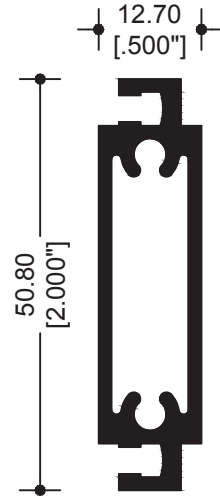

7101
MOSQUITERO
INTERMEDIO

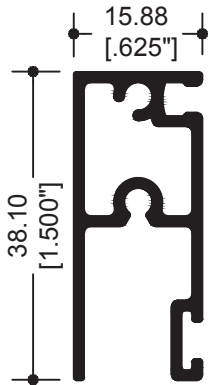

10358
MOSQUITERO

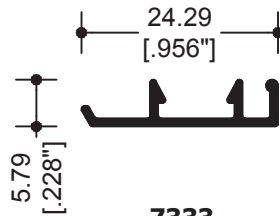

7333
MOSQUITERO

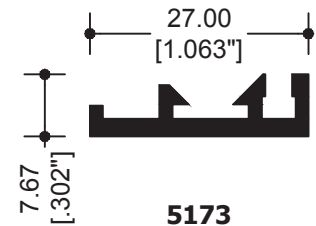

5173
MOSQUITERO

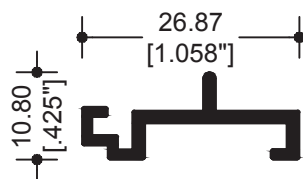

9966
ADAPTADOR MOSQUITERO

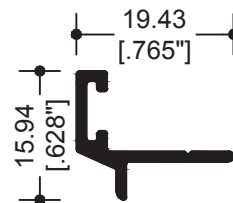

10220
ADAPTADOR OXXO

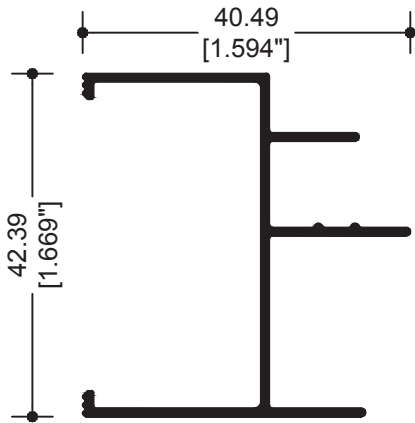

10570
JAMBA

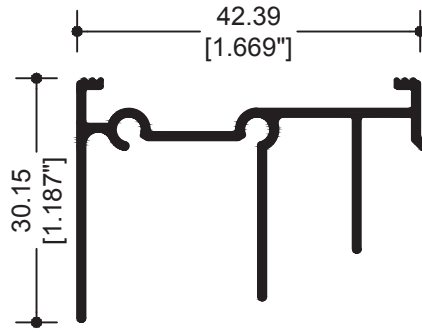

10568
CABEZAL

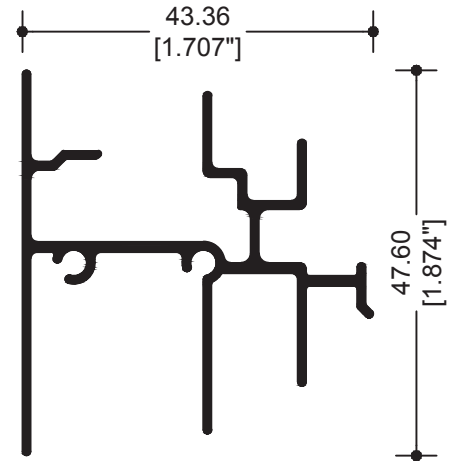

12797
RIEL Y CABEZAL

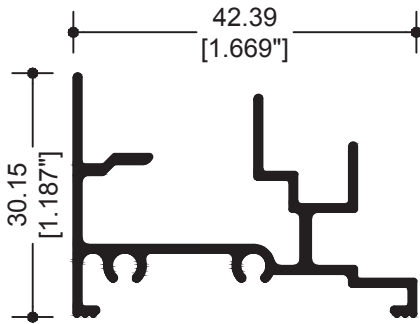

20569
RIEL

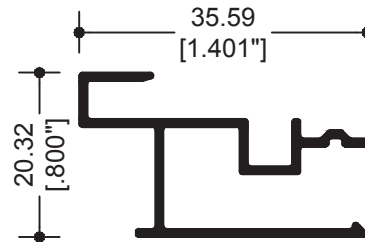

19272
TRASLAPE

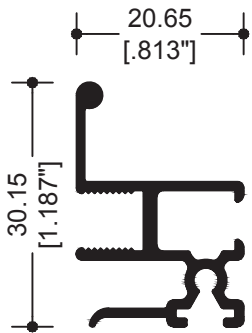

10571
CERCO MÓVIL

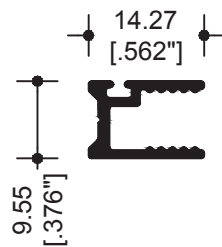

10574
CERCO FIJO

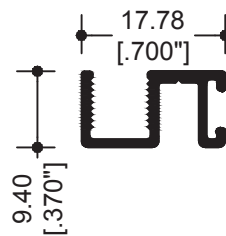

20572
CERCO Y ZOCLO

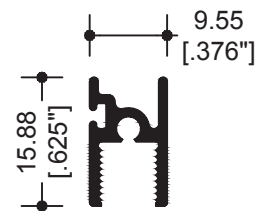

10575
ZOCLO

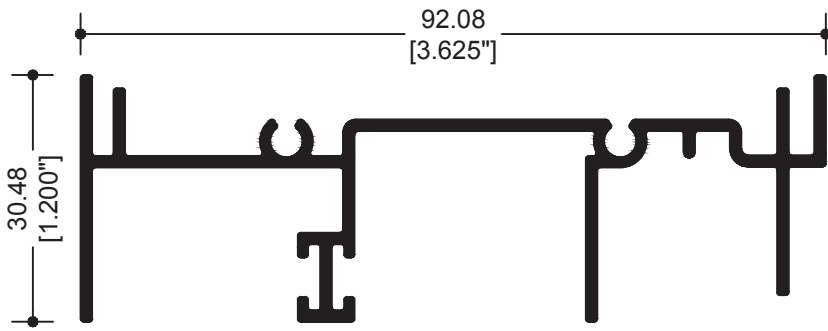

7109
CABEZAL CONTRAMARCO CORREDIZA

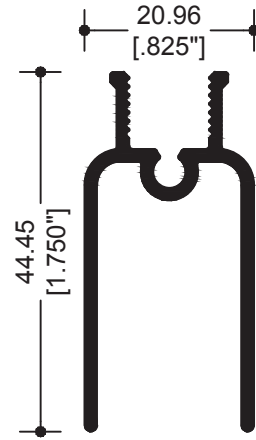

7108
CABEZAL Y ZOCLO

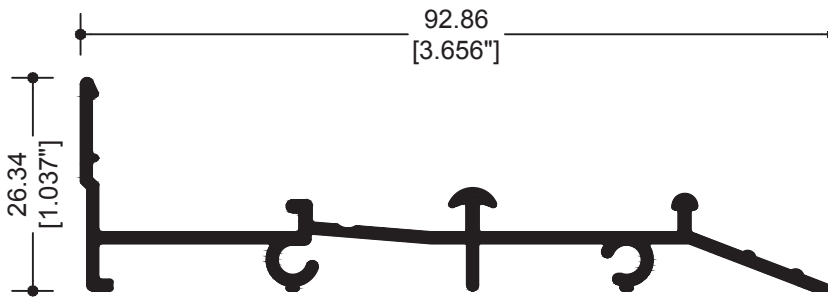

7110
RIEL CONTRAMARCO CORREDIZO

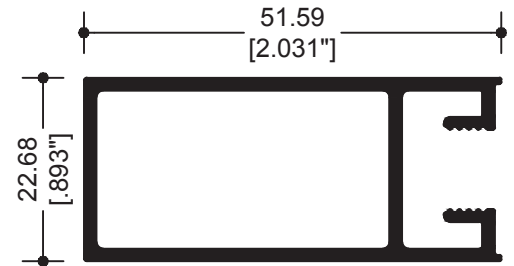

7105
CERCO CHAPA

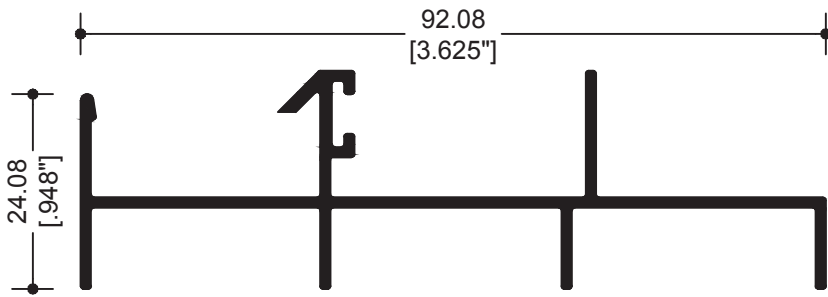

27111
JAMBA PARA CORREDIZA

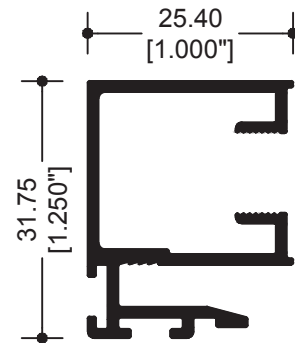

7106
CERCO TRASLAPE

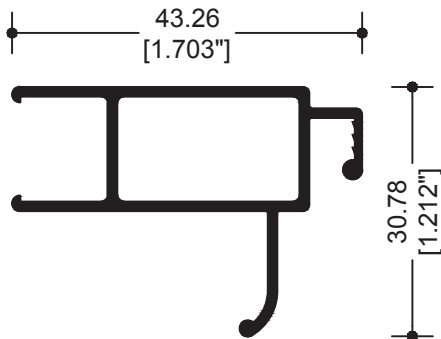

7112
VERTICAL MOSQUITERO

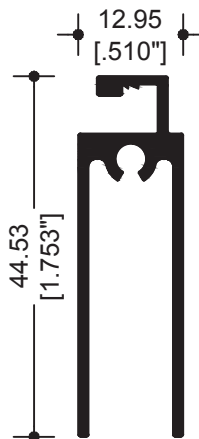

7104
MOSQUITERO

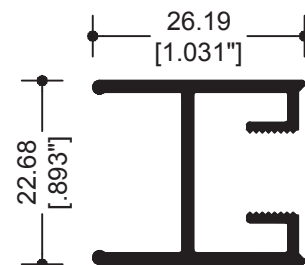

7107
CERCO FIJO

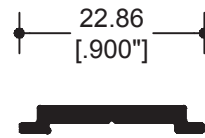
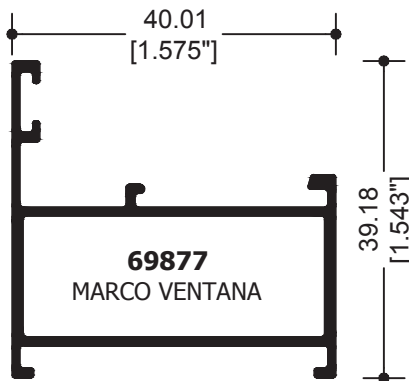
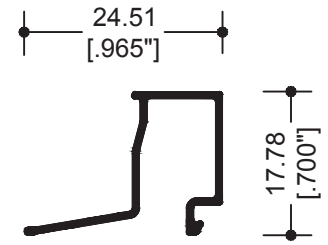
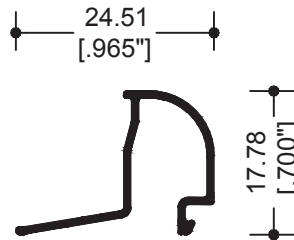
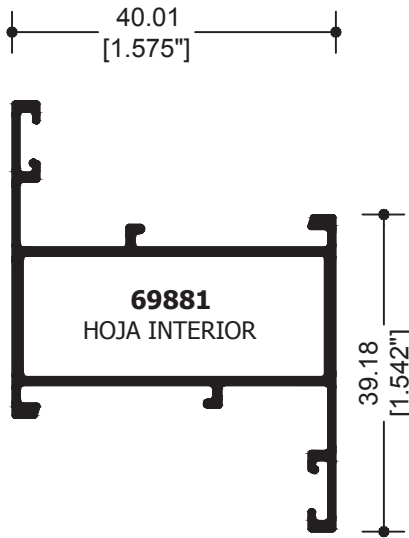
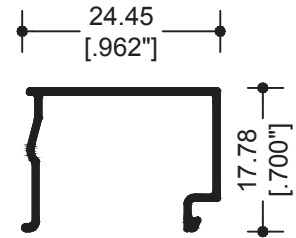
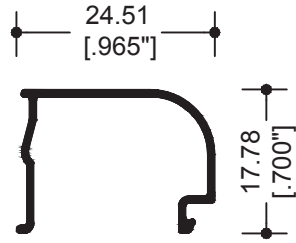
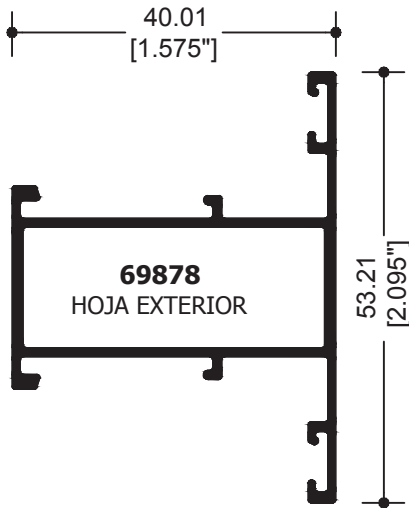

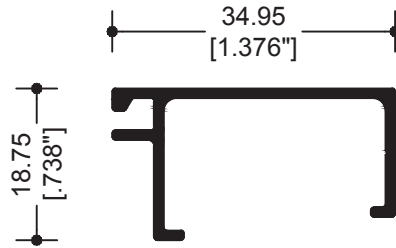

28939
JUNQUILLO

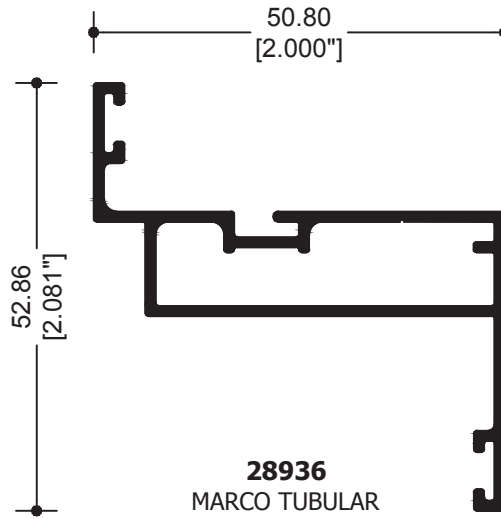

28936
MARCO TUBULAR

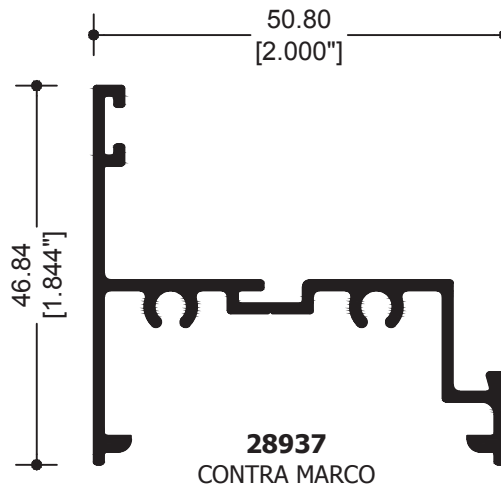

28937
CONTRA MARCO

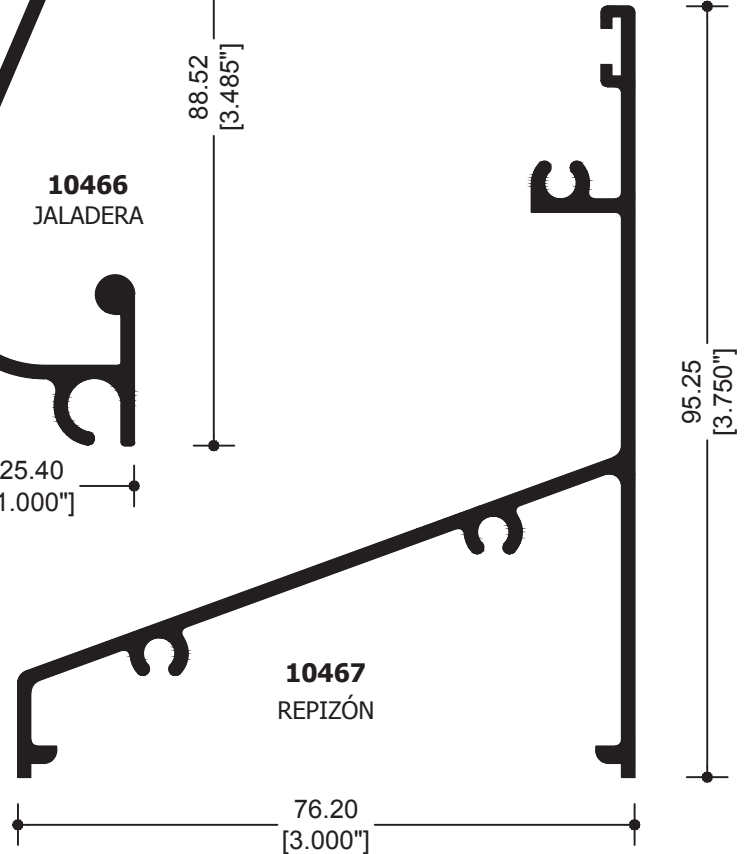
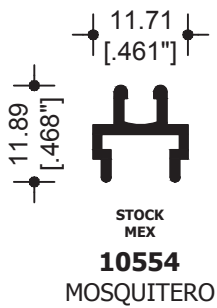
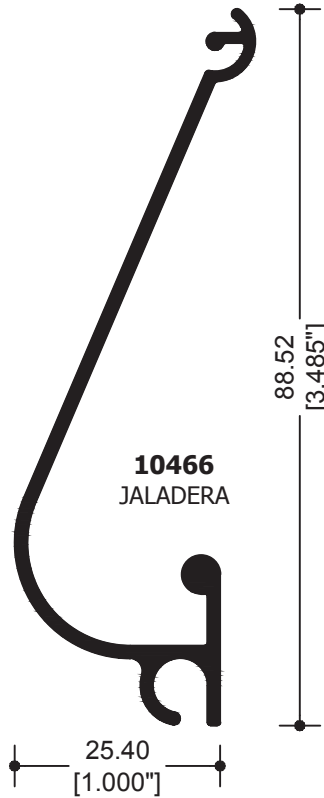
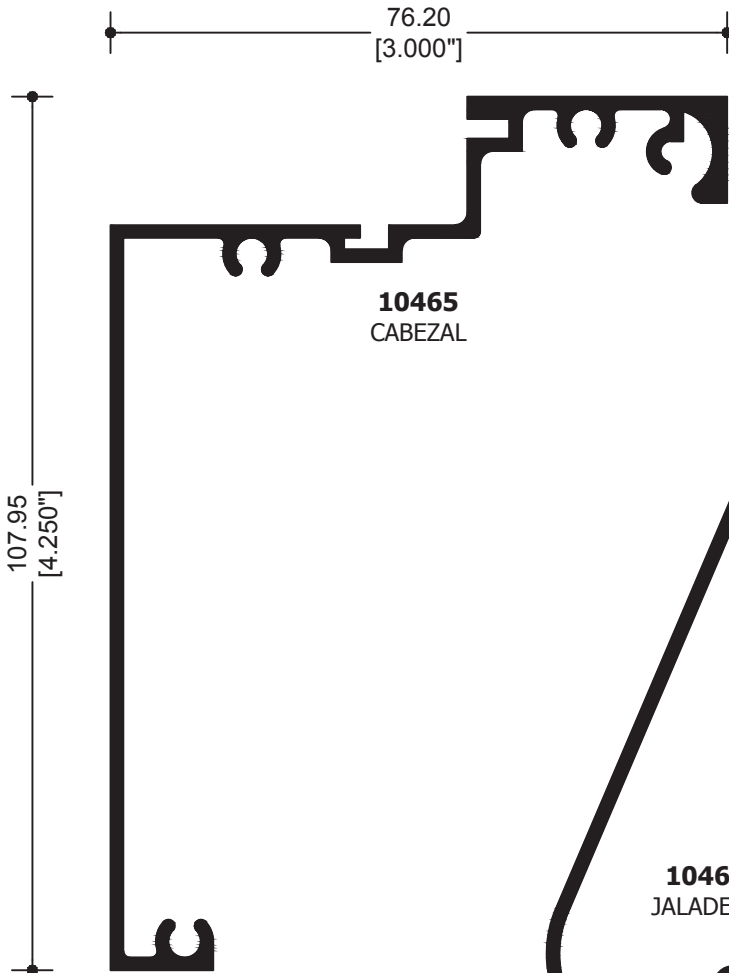
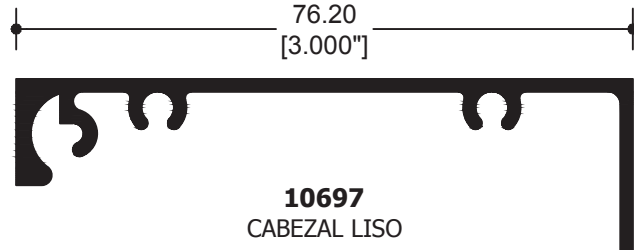
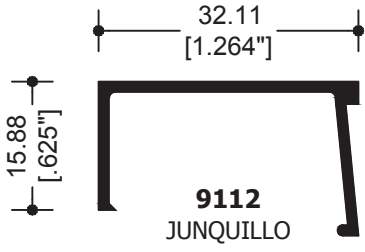

107.95
[4.250"]

95.25
[3.750"]

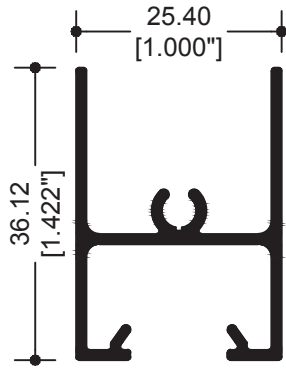

67836
CABEZAL

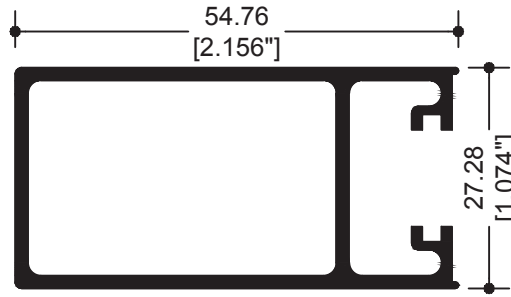

9236
CERCO CHAPA

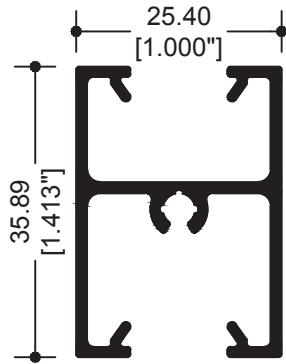

69082
INTERMEDIO

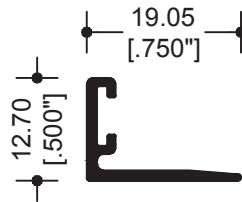

11032
BATIENTE

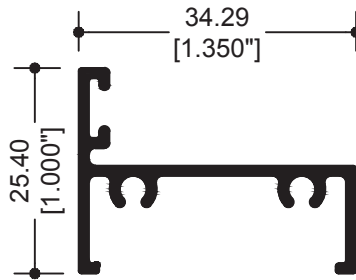

33087
MARCO PARA PUERTA

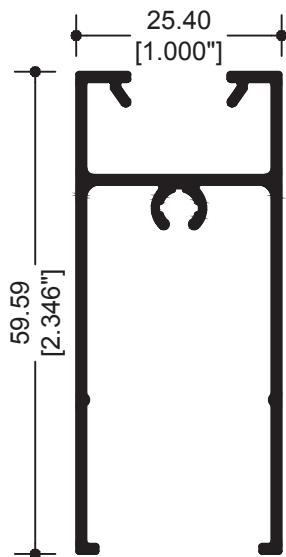

67835
ZOCCO

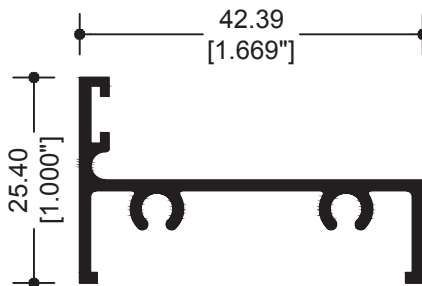

68550
MARCO PARA PUERTA

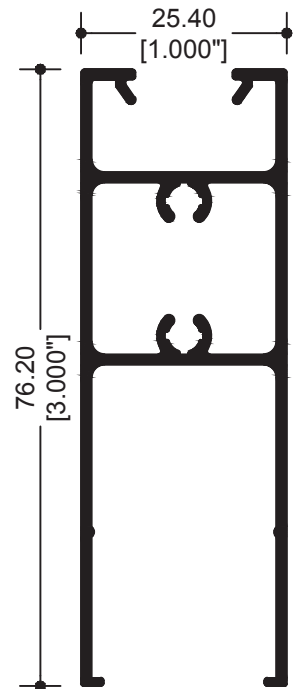

67842
ZOCCO

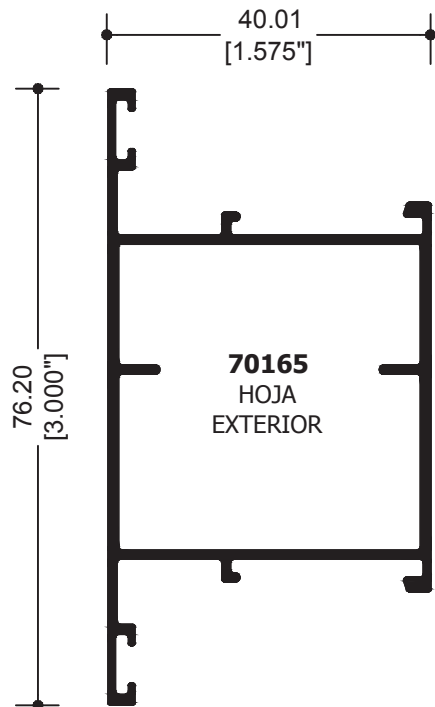
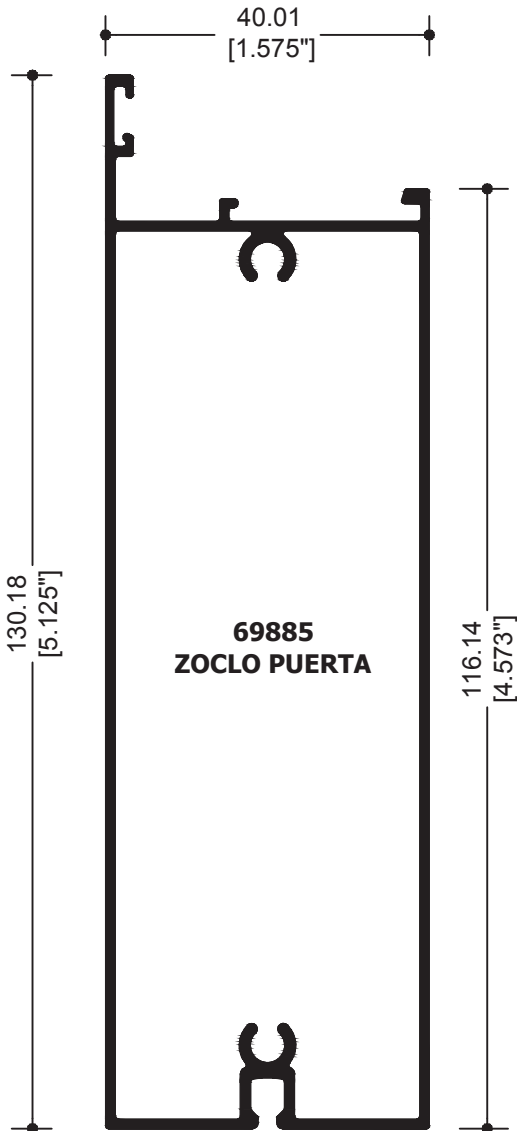
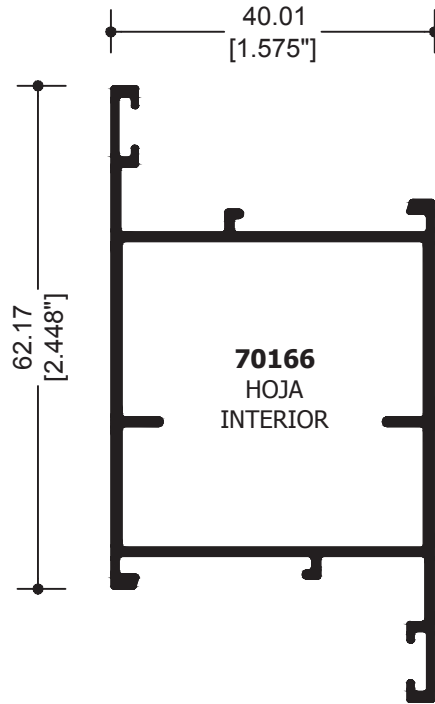
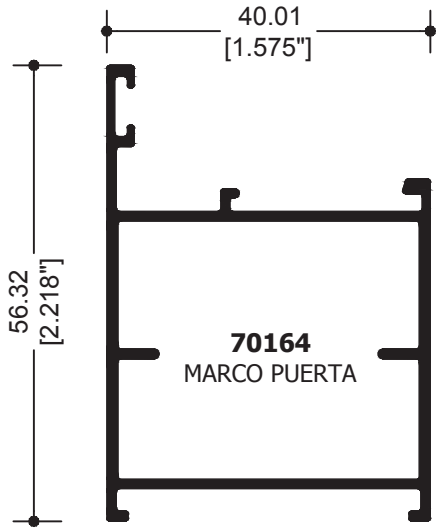

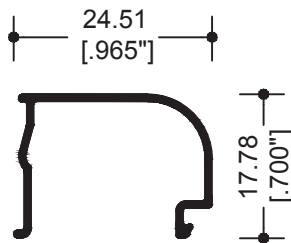
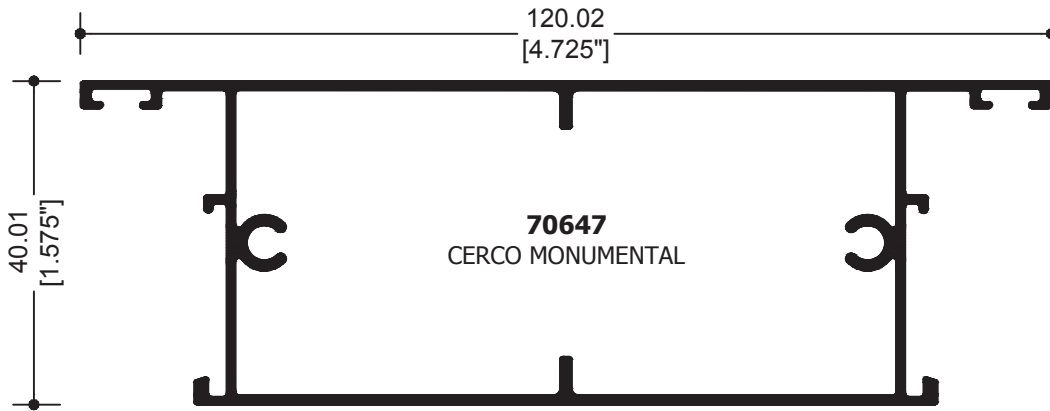

69891
JUNQUILLO
CONCAVO
SENCILLO

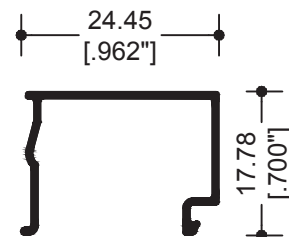

69890
JUNQUILLO
CUADRADO
SENCILLO

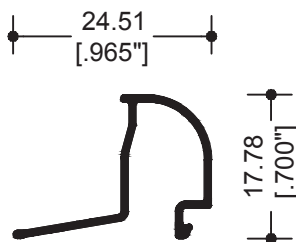

69887
JUNQUILLO
CONCAVO
DOBLE

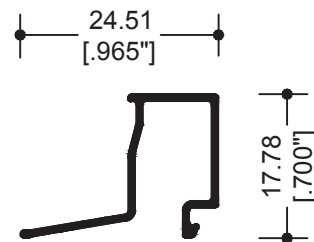

69888
JUNQUILLO
CUADRADO
DOBLE

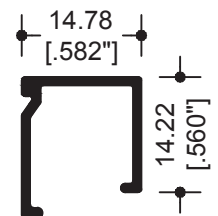
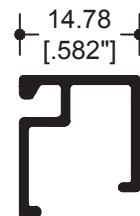
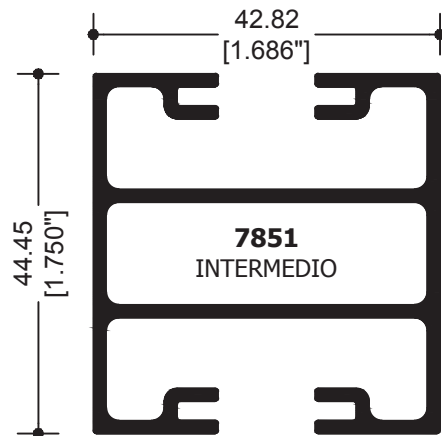
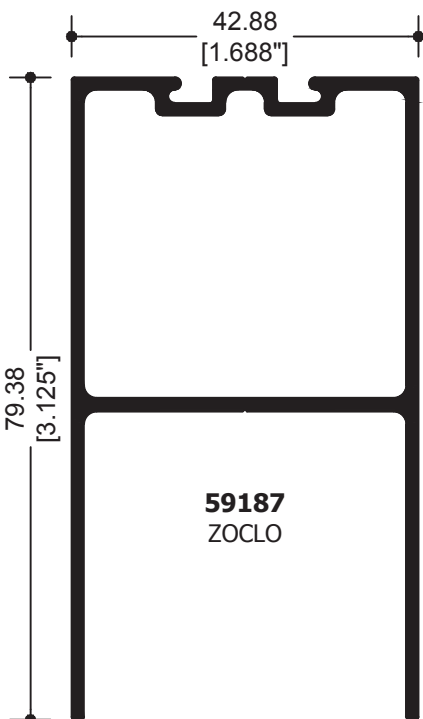
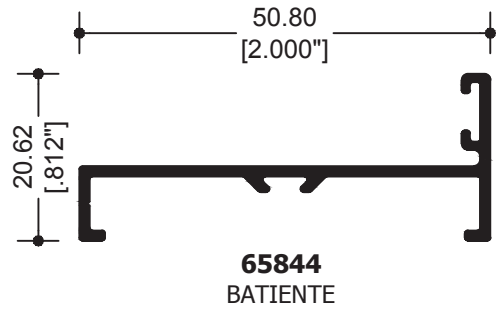
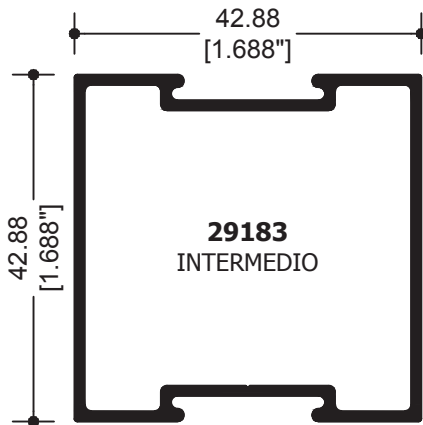
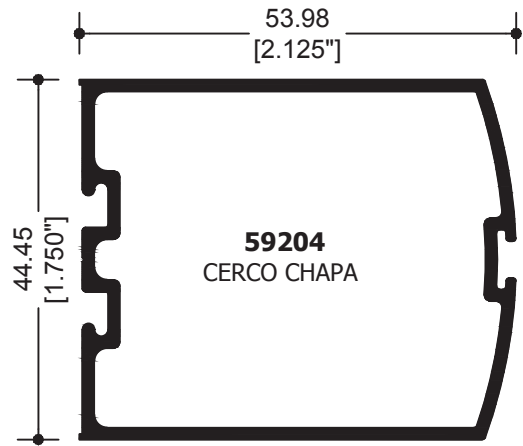
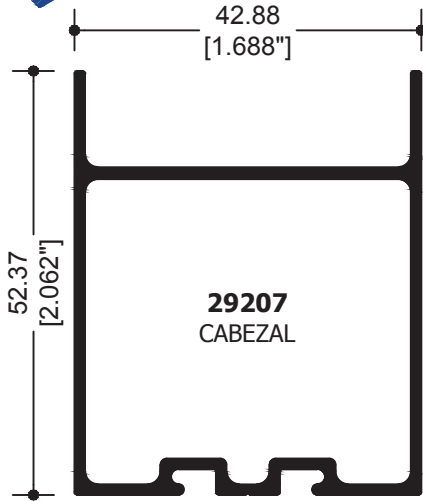

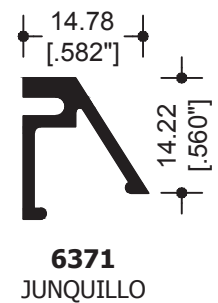
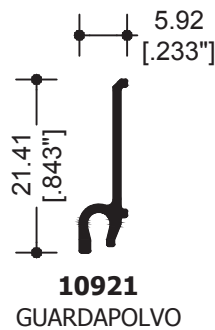
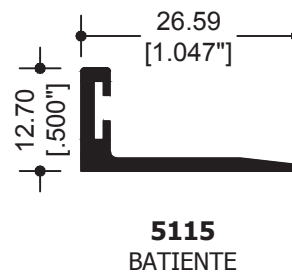
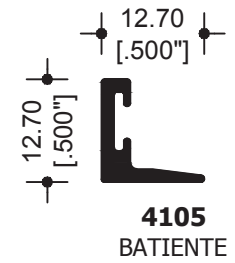
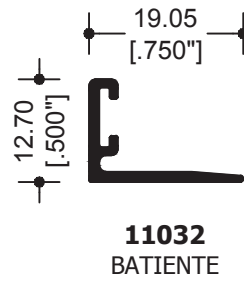
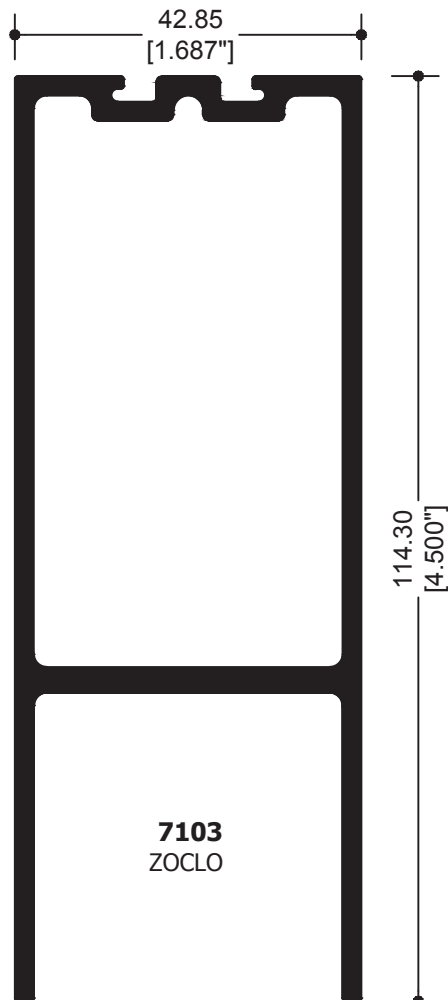
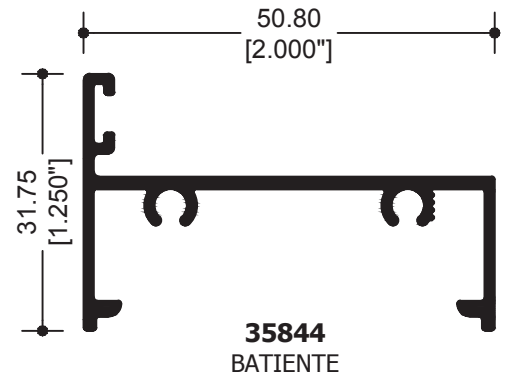
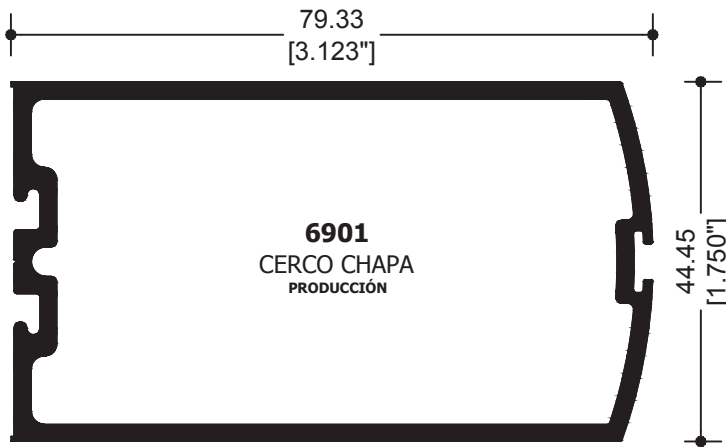

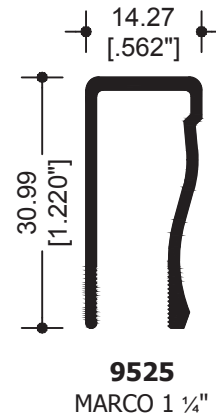
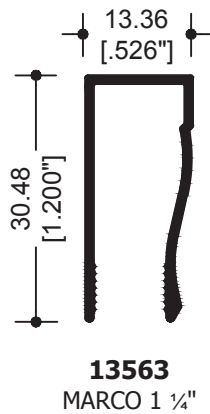
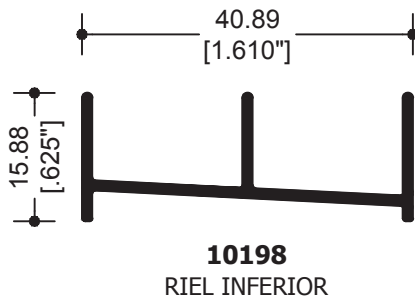
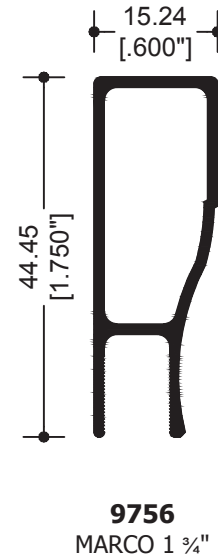
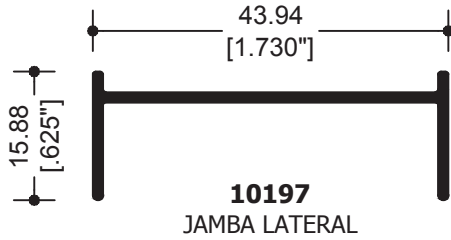
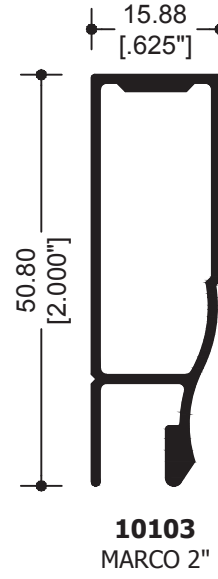
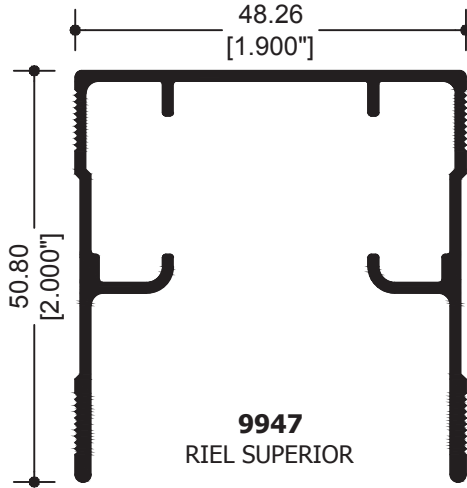

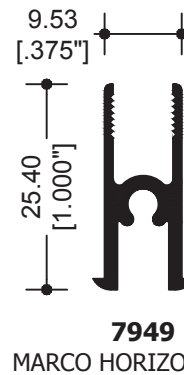
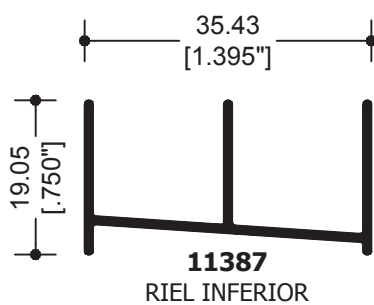
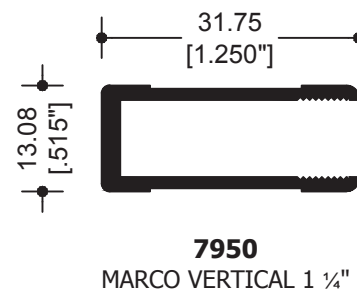
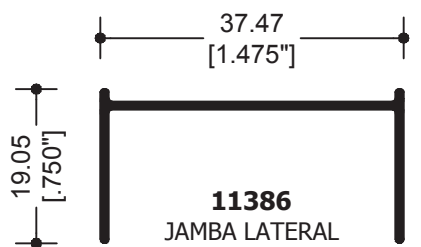
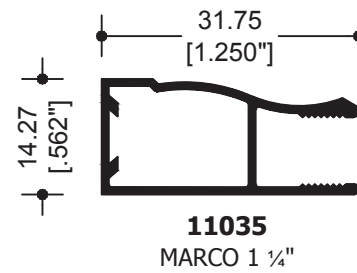
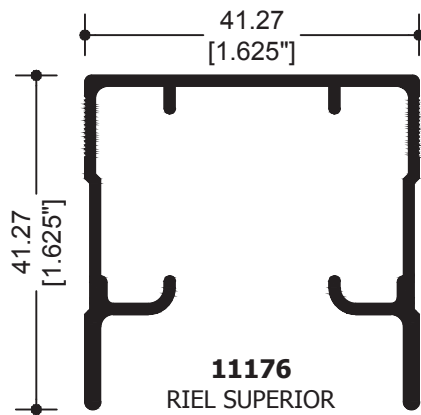
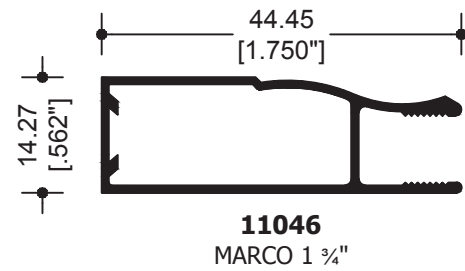
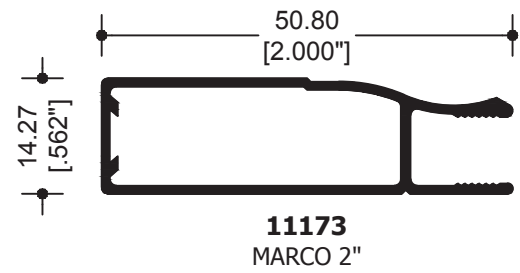
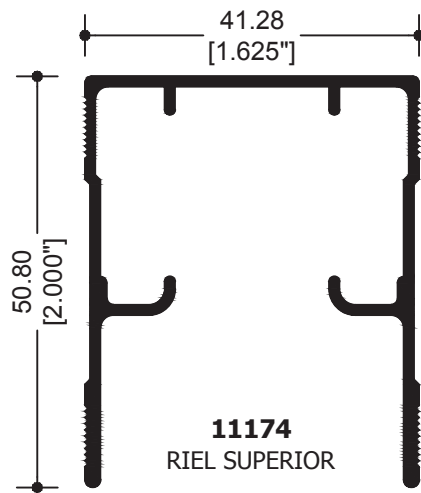

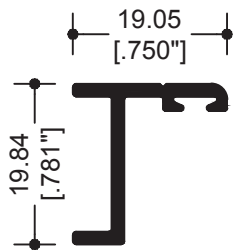

4127
BATIENTE

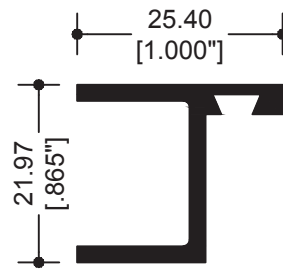

7102
BATIENTE

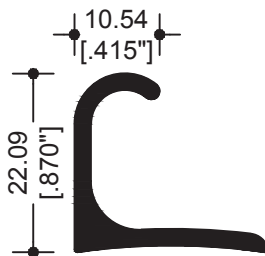

4154
JALADERA

APARADORES Y VITRINAS

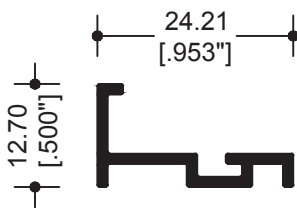

67013
BASE

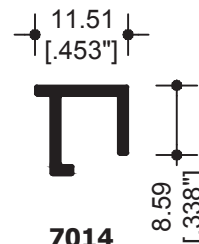

7014
JUNQUILLO

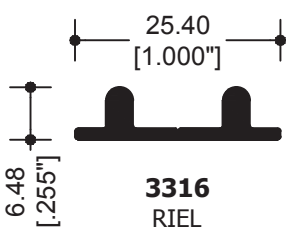

3316
RIEL

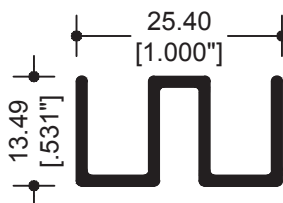

63329
GUÍA

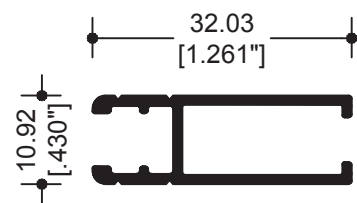

53358
ZAPATA

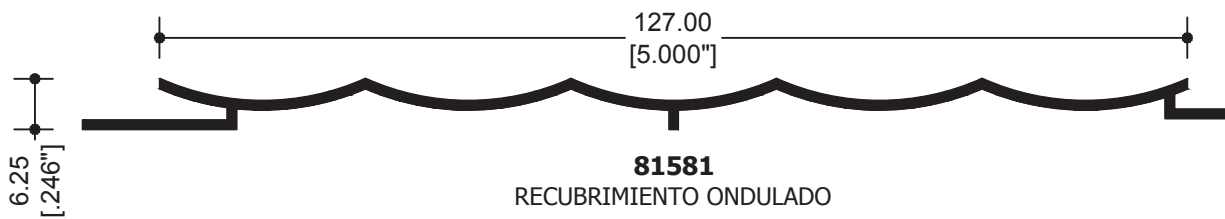
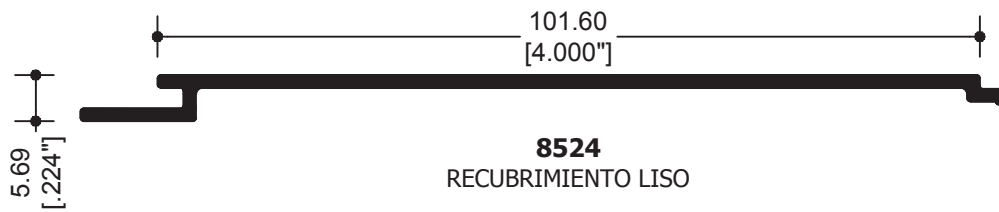
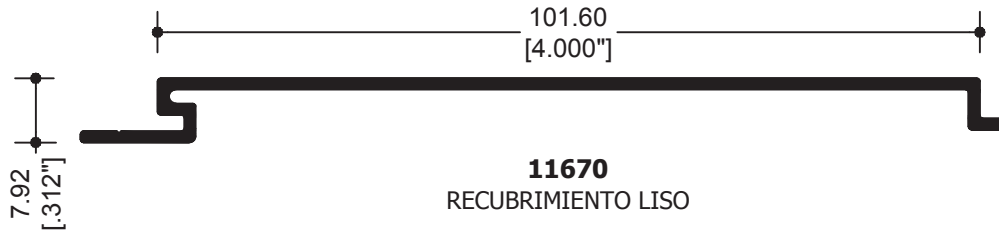

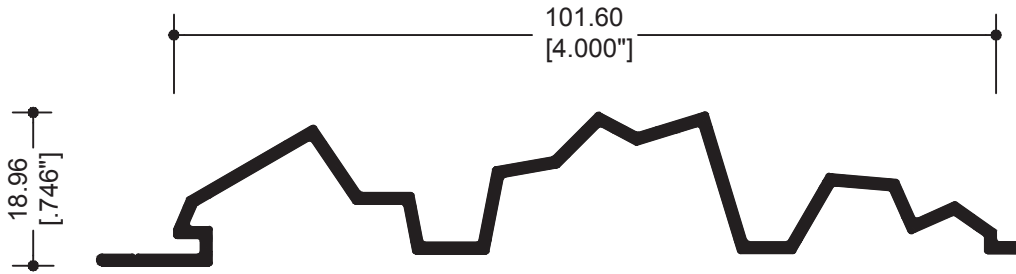

11672
RECUBRIMIENTO GRAFICADO
PRODUCCIÓN

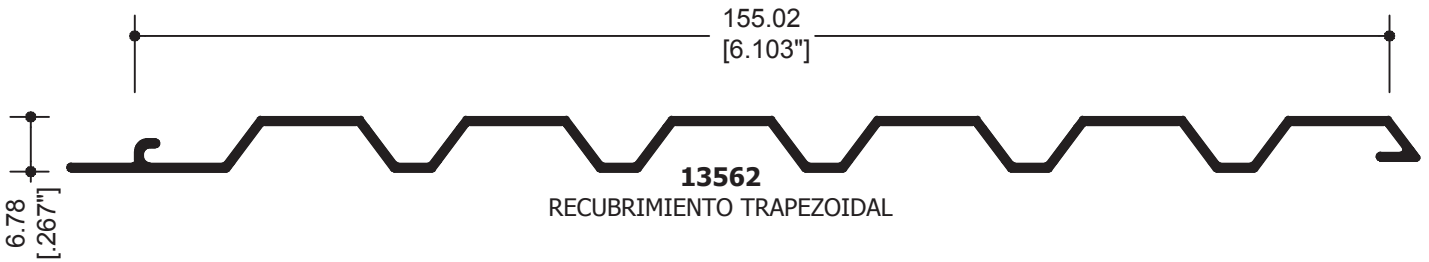

13562
RECUBRIMIENTO TRAPEZOIDAL

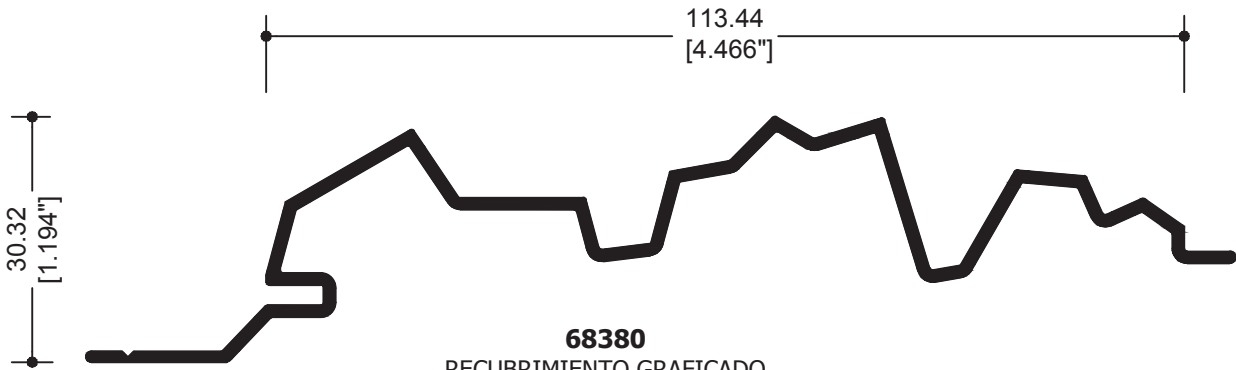

68380
RECUBRIMIENTO GRAFICADO

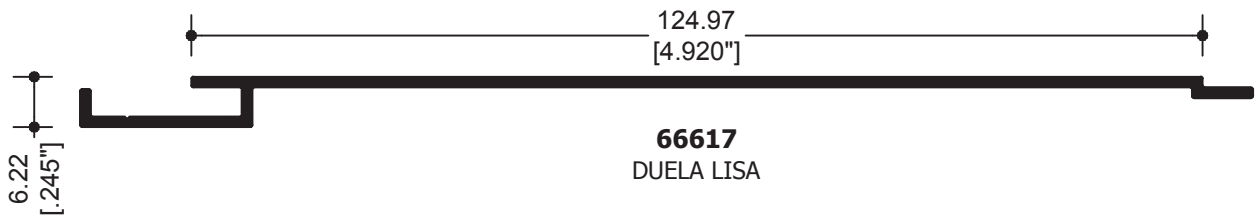
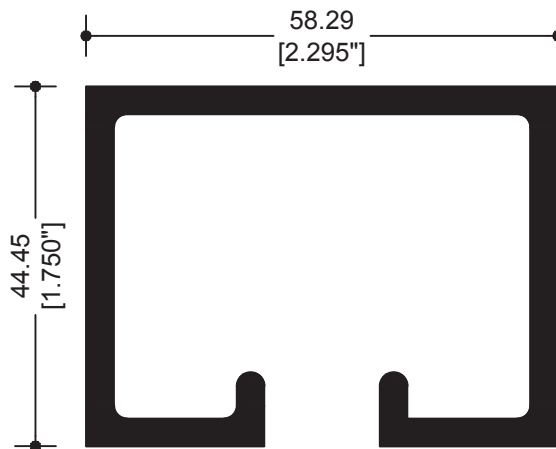
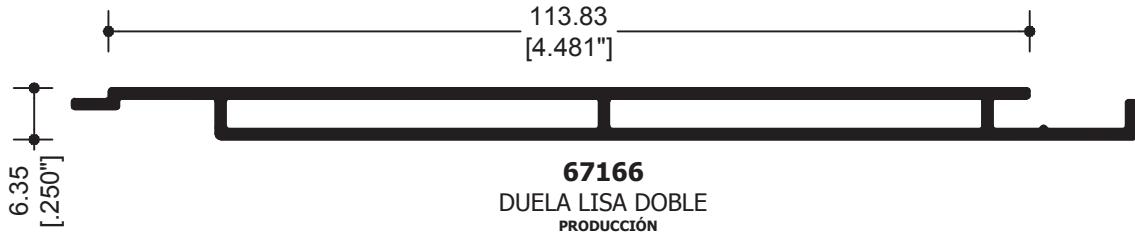

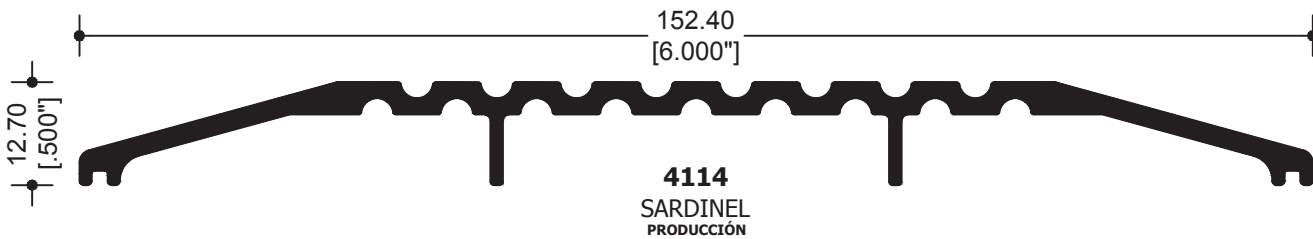
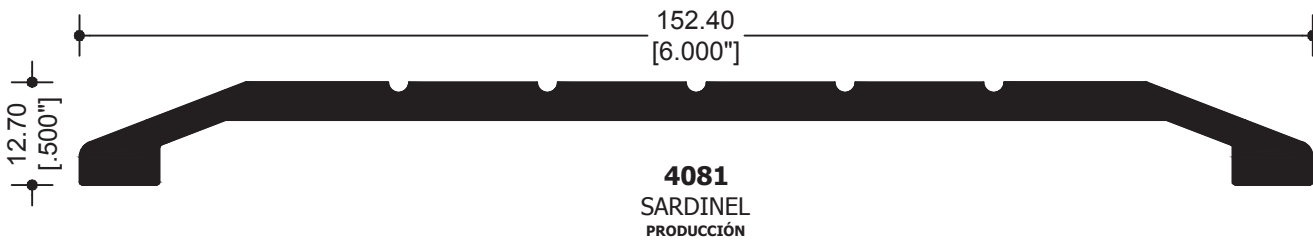
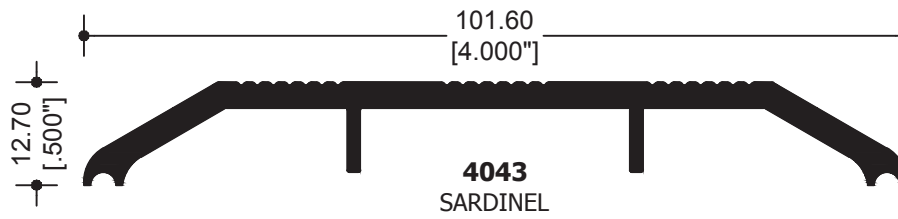
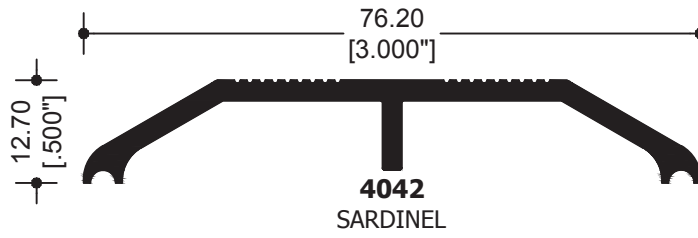

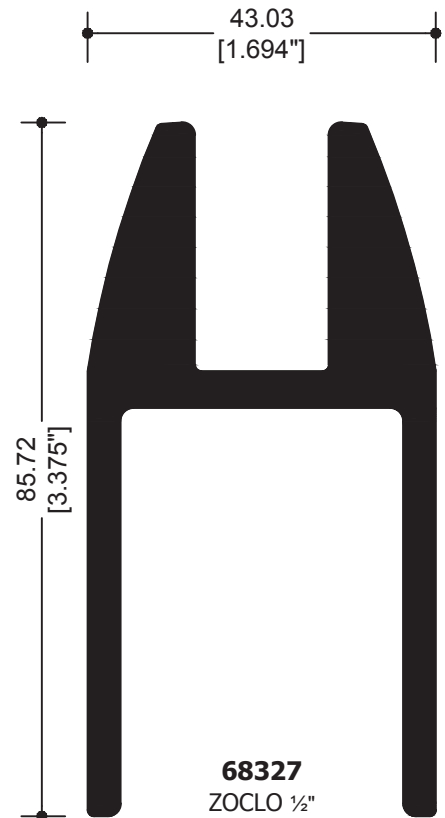
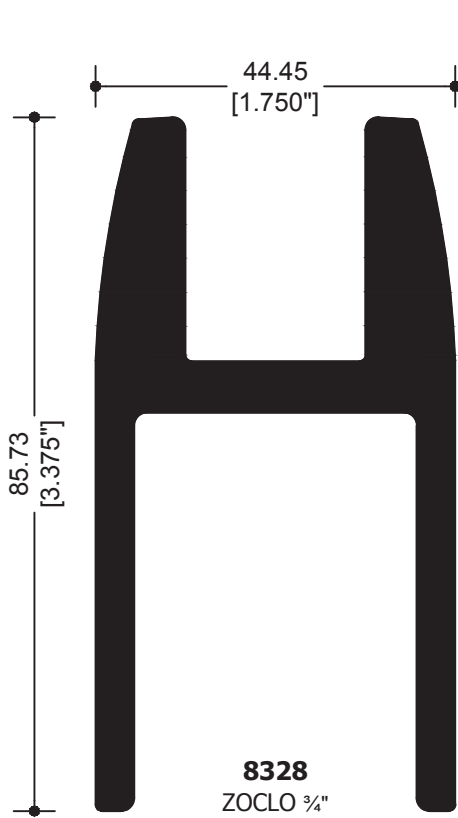

REPIZÓN

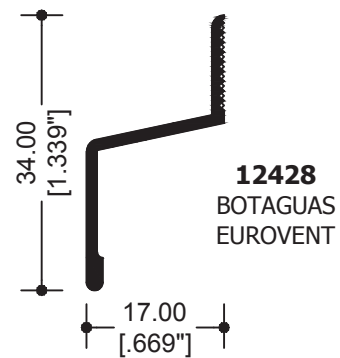
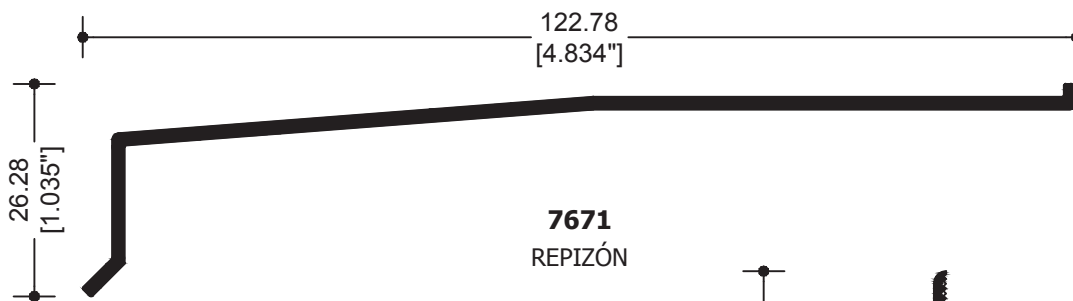

79.38
[3.125"]

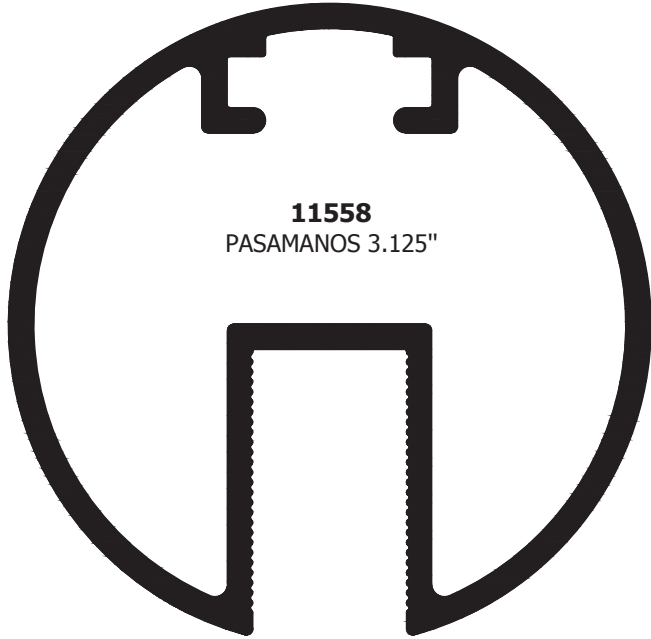

60.00
[2.362"]



101.60
[4.000"]



76.20
[3.000"]

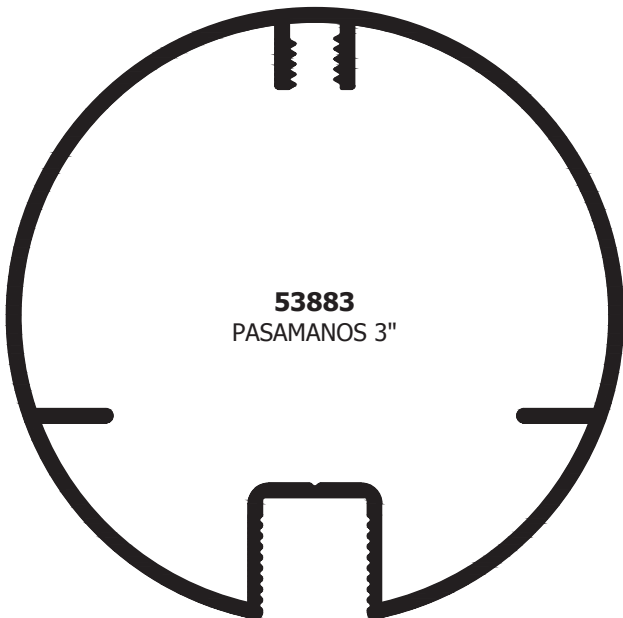

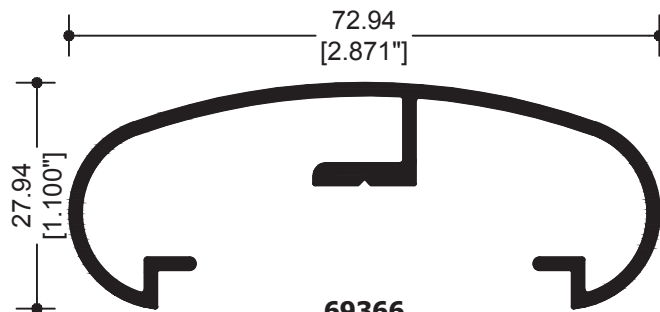
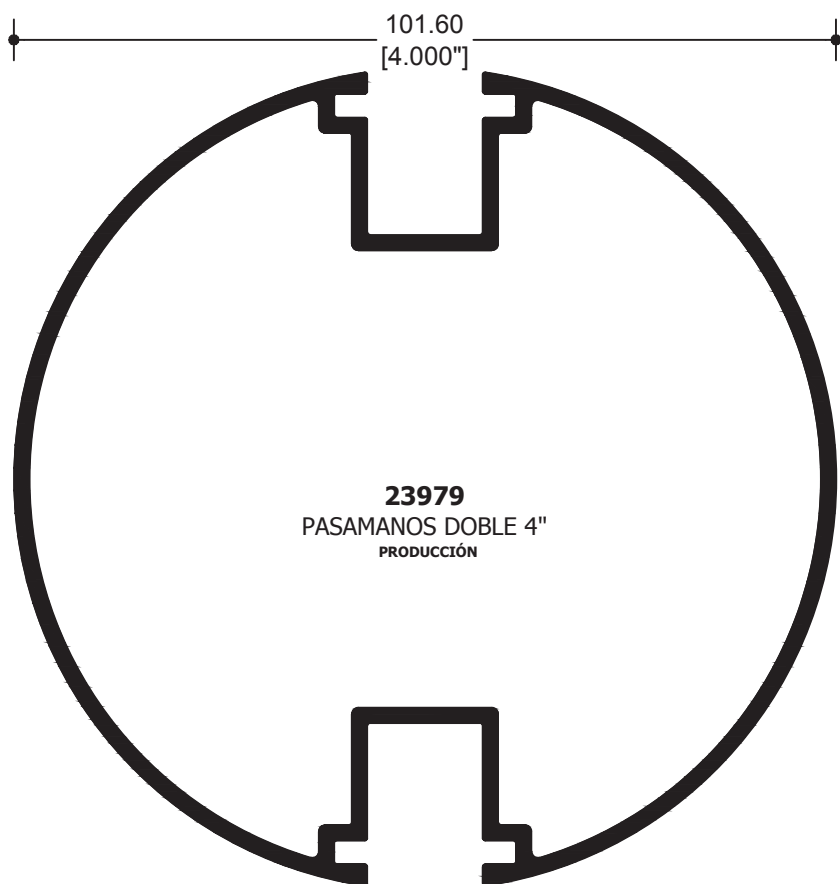

69366
PASAMANOS 3"

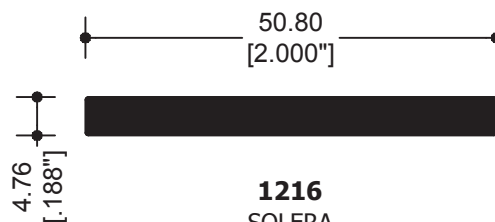

1216
SOLERA

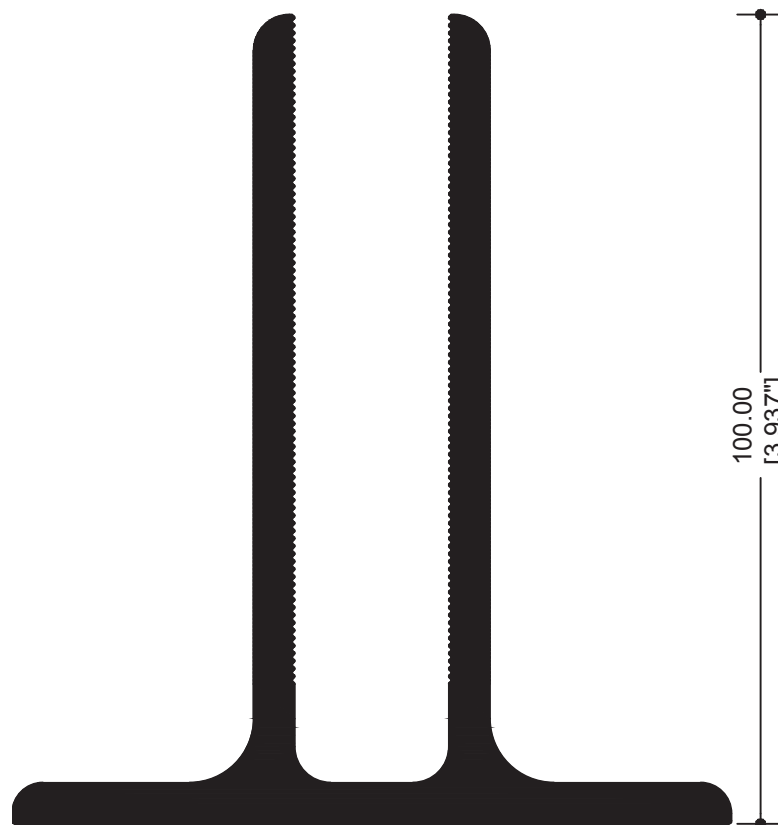
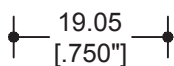

69776
ZOCLO DE BARANDAL

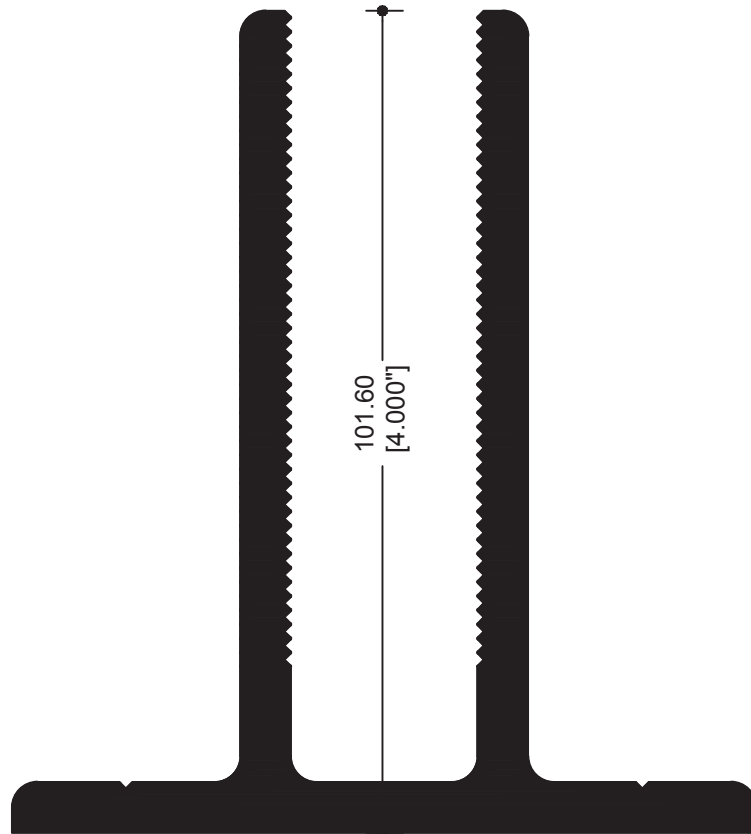
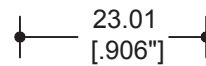

28009
ZOCLO DE BARANDAL

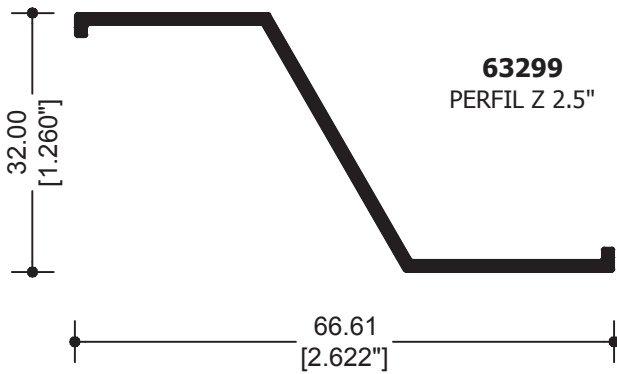
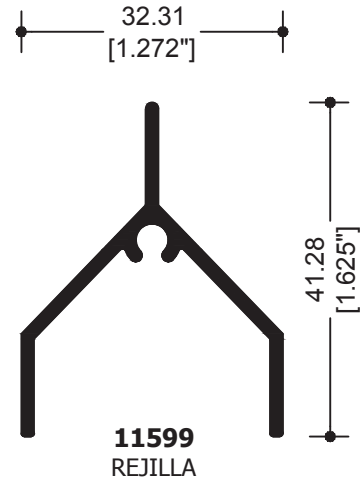
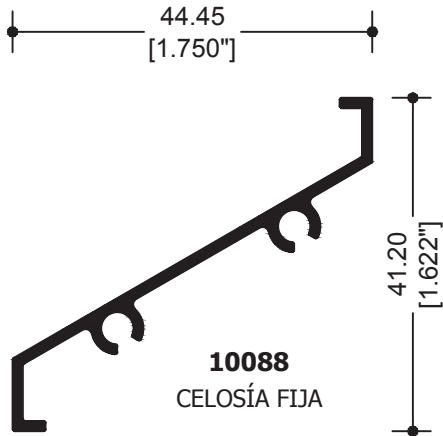
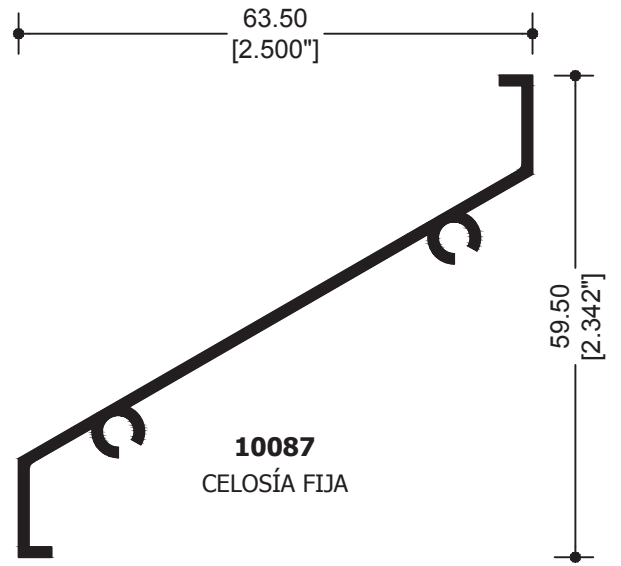
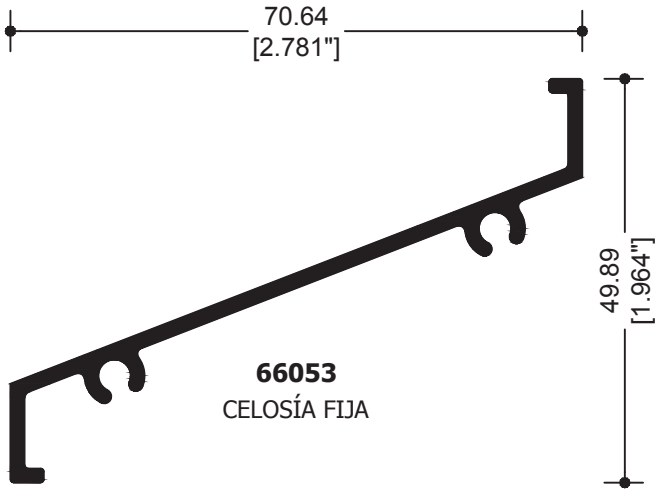

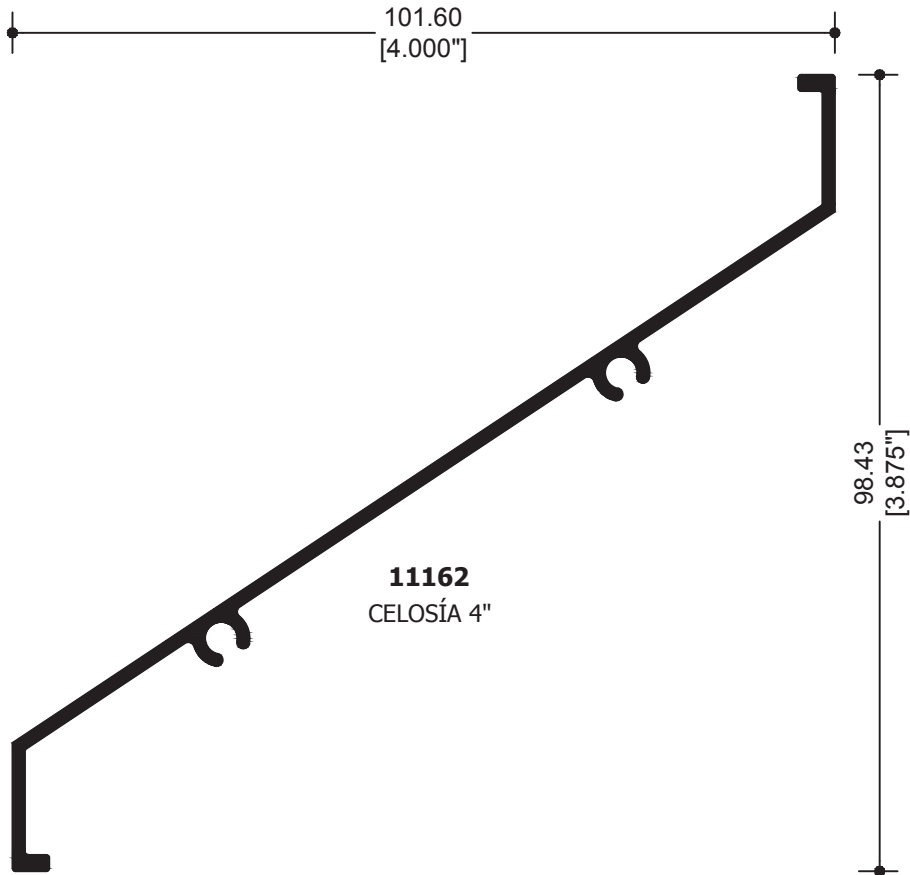
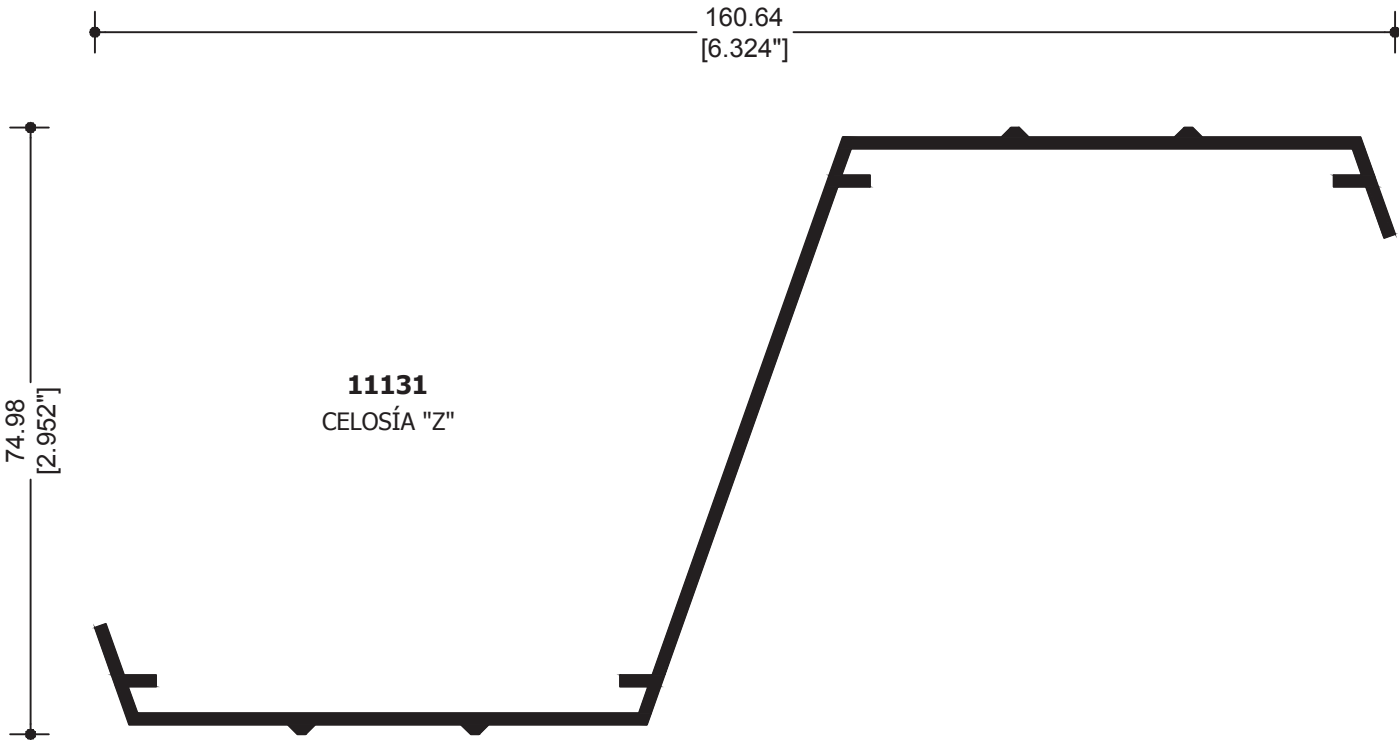

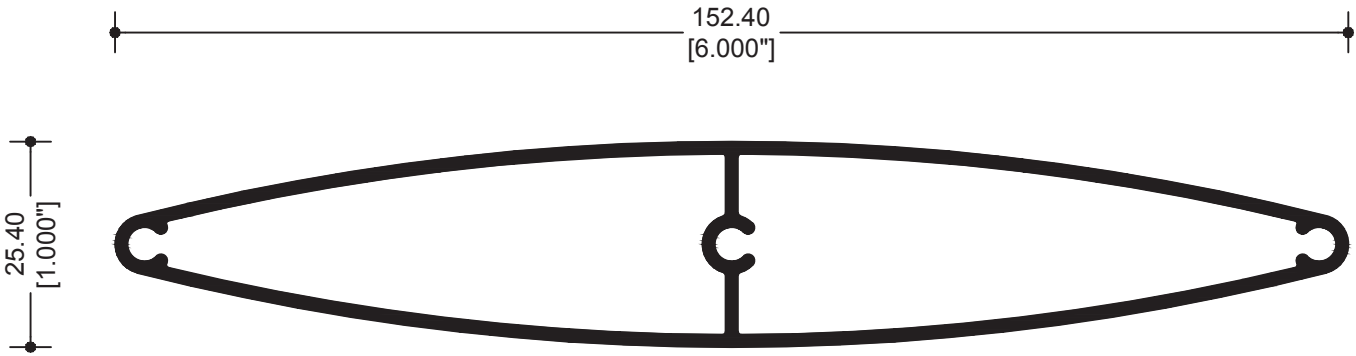

67362
CELOSÍA 6"

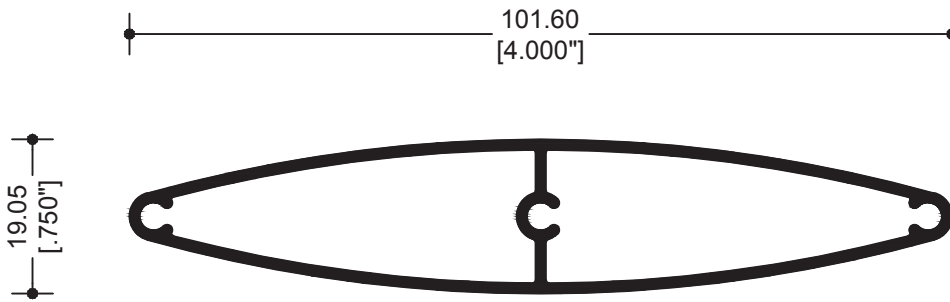

67363
CELOSÍA

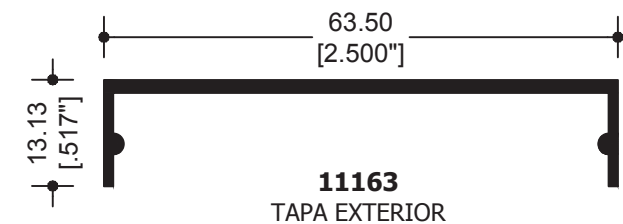

11163
TAPA EXTERIOR

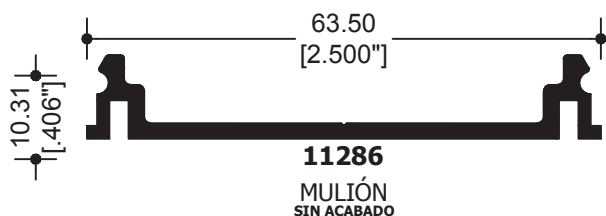

11286
MULIÓN
SIN ACABADO

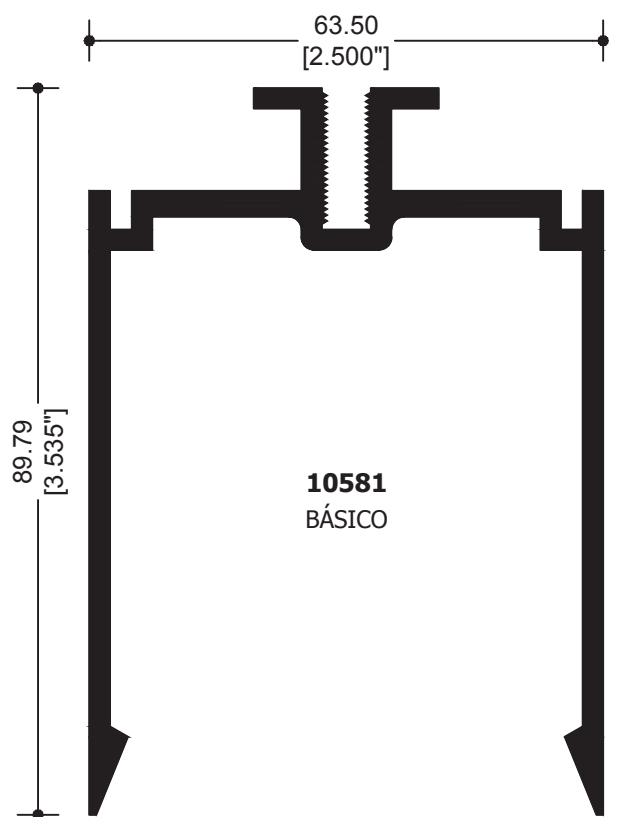

10581
BÁSICO

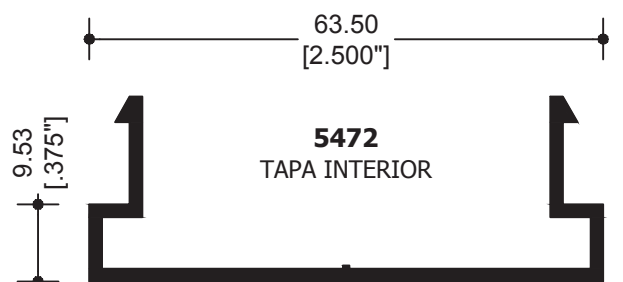

5472
TAPA INTERIOR

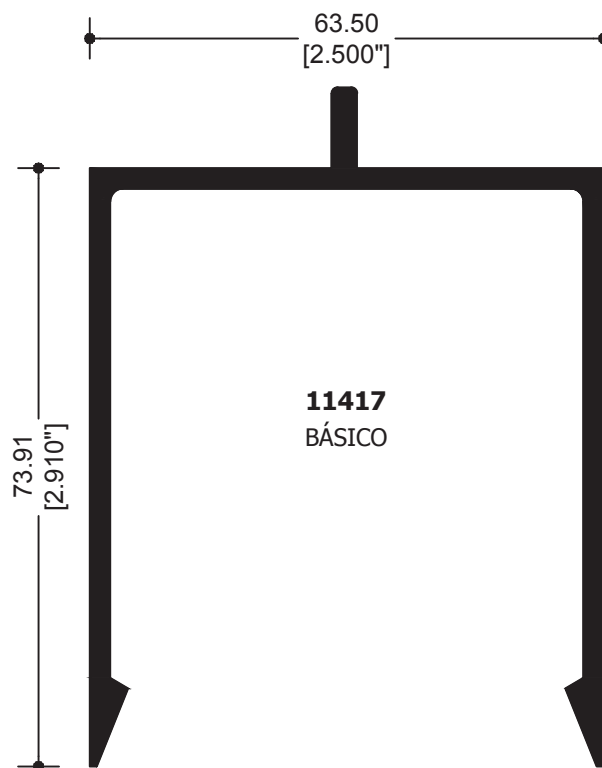

11417
BÁSICO

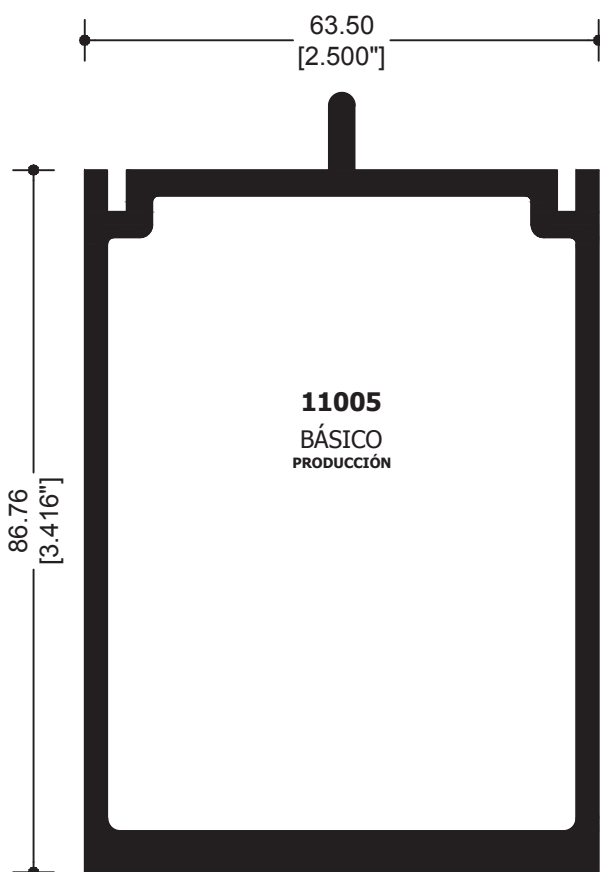

11005
BÁSICO
PRODUCCIÓN

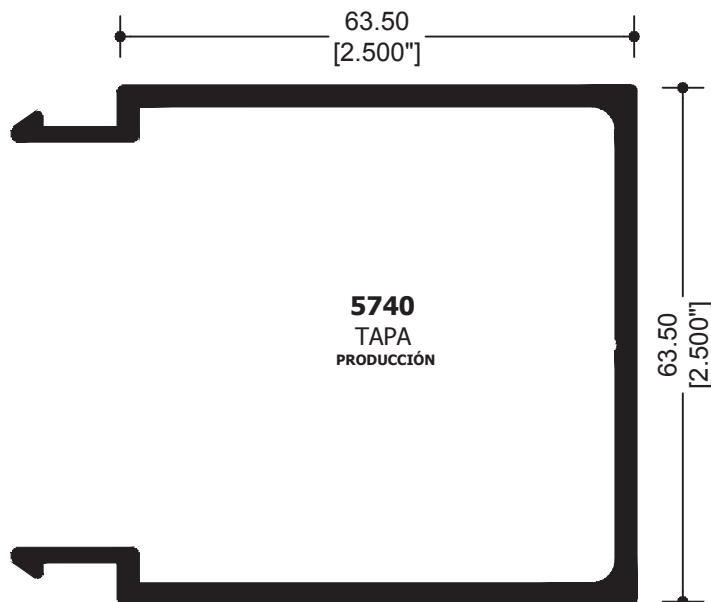
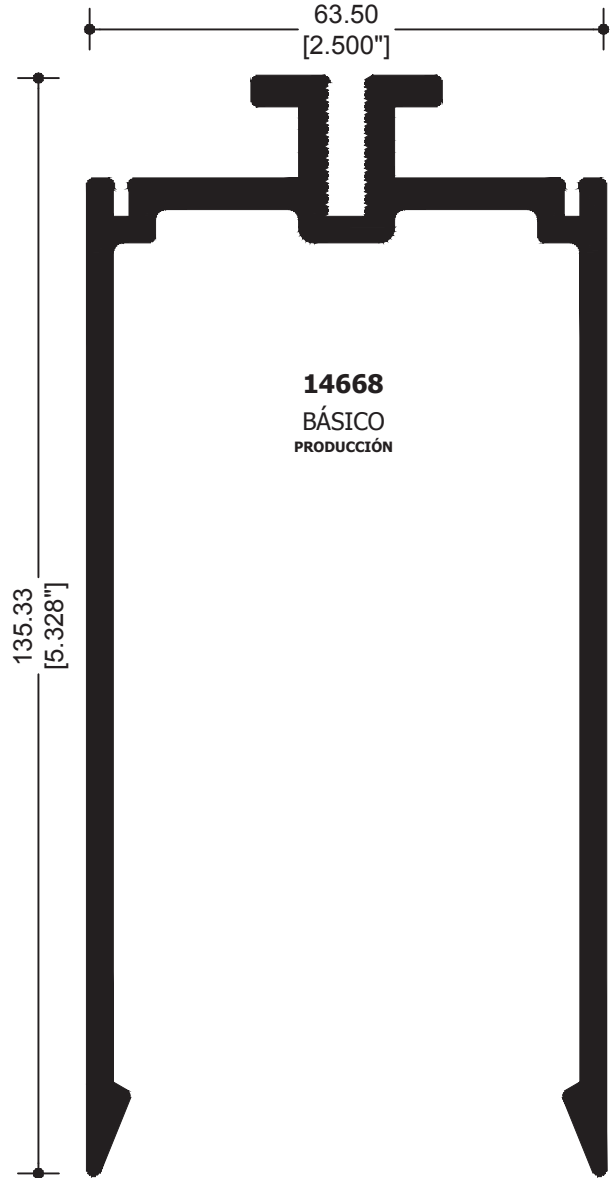
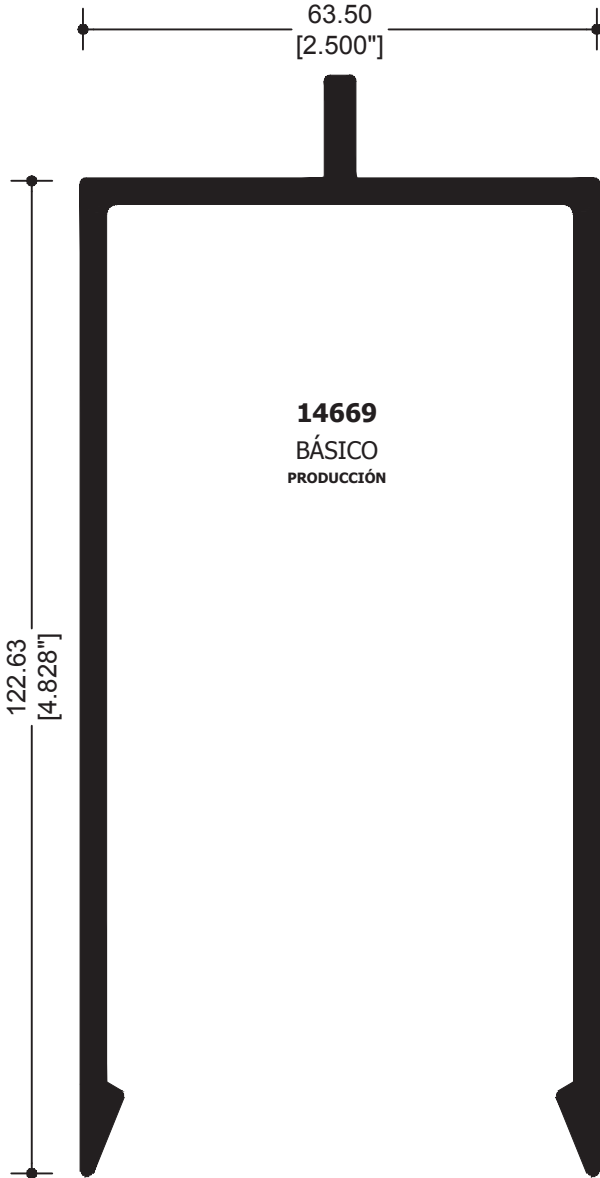

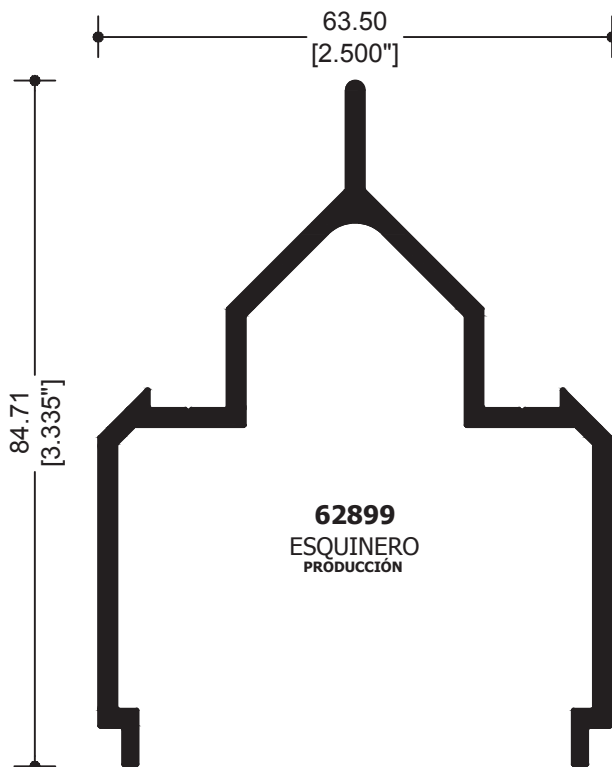
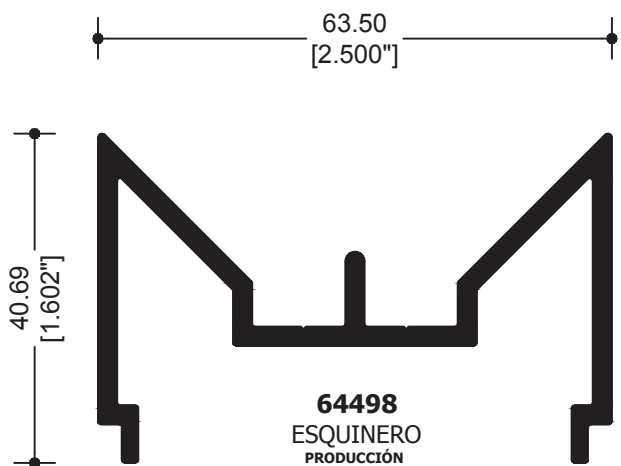
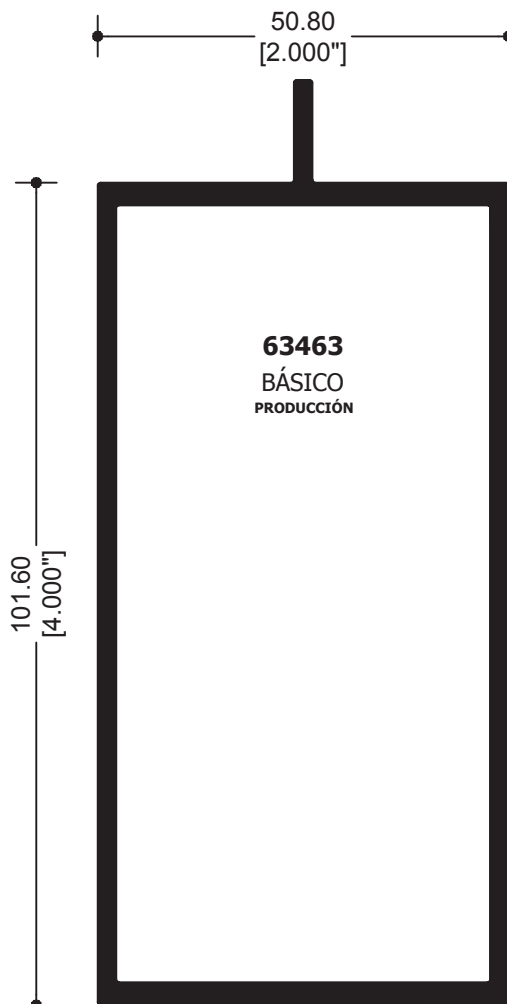
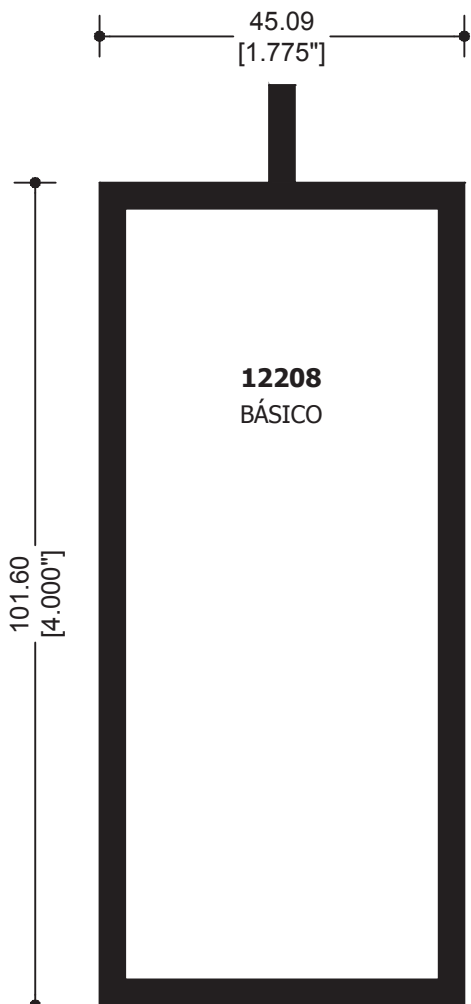

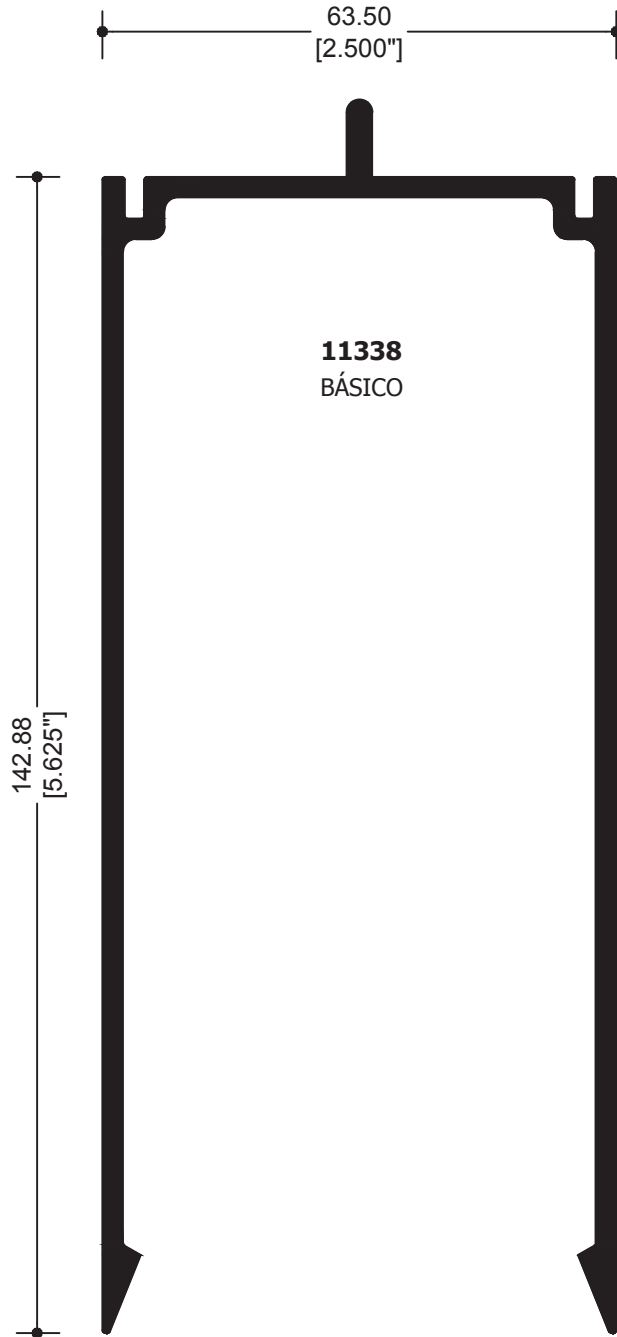

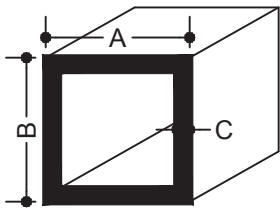

TUBO CUADRADO

CLAVE	MEDIDAS EN PULGADAS		
	A	B	C
50170	0.500	0.500	.050
2351	0.750	0.750	.050
22036	0.750	0.750	.062
62488	1.000	1.000	.039
11161	1.000	1.000	.045
2362	1.000	1.000	.050
11154	1.250	1.250	.049
2354	1.250	1.250	.065
62489	1.500	1.500	.044
2363	1.500	1.500	.057
22268	1.500	1.500	.125
11093	1.750	1.750	.050
2364	1.750	1.750	.057
11156	2.000	2.000	.054
2356	2.000	2.000	.065
2369	3.000	3.000	.058
2358	3.000	3.000	.083
2365	4.000	4.000	.125

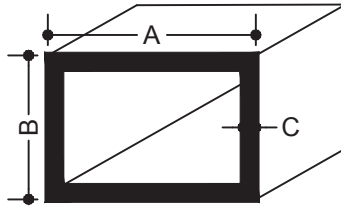

TUBO RECTANGULAR

CLAVE	MEDIDAS EN PULGADAS		
	A	B	C
52500	1.000	0.500	.048
22049	1.000	0.500	.062
2500	1.000	0.500	.065
62515	1.500	0.750	.045
2515	1.500	0.750	.050
2514	1.500	1.000	.062
62521	2.000	1.000	.044
2521	2.000	1.000	.057
11099	2.500	1.250	.055
2513	2.500	1.250	.062
65321	3.000	1.000	.048
22242	3.000	1.000	.060
2516	3.000	1.000	.083
62509	3.000	1.500	.044
19613	3.000	1.750	.050
11122	3.000	1.750	.058
22026	3.000	1.750	.075
2522	3.000	1.750	.078
22273	3.000	2.000	.125
14729	4.000	1.750	.060
2520	4.000	1.750	.078
22107	4.000	1.750	.109
22017	4.000	1.750	.125
2518	4.000	2.000	.109

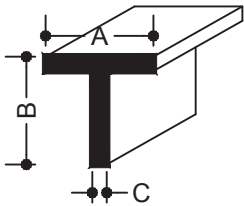

TEES

CLAVE	MEDIDAS EN PULGADAS		
	A	B	C
17256	0.750	0.750	.062
1613	1.000	1.000	.038
1611	1.000	1.000	.050
1602	1.000	1.000	.062
17231	1.000	1.000	.125

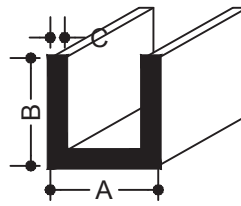

CANALES

CLAVE	MEDIDAS EN PULGADAS		
	A	B	C
1432	0.350	0.350	.035
4688	0.375	0.375	.063
1433	0.500	0.500	.030
65317	0.500	0.500	.040
18081	0.500	0.500	.063
40156	0.750	0.750	.063
17003	0.750	0.750	.125
1463	1.000	1.000	.063
17977	1.000	1.000	.125

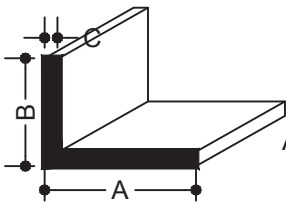

ÁNGULOS LADOS DESIGUALES

CLAVE	MEDIDAS EN PULGADAS		
	A	B	C
16	1.000	0.500	.125
0622	1.500	0.750	.125
1364	1.500	1.000	.125
20	2.000	1.000	.125

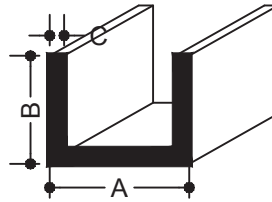

CANALES LADOS DESIGUALES

CLAVE	MEDIDAS EN PULGADAS		
	A	B	C
4005	0.500	0.750	.125
1403	0.625	0.500	.063
65498	0.750	0.500	.125
1411	1.000	0.500	.125
18490	1.500	0.500	.125
1428	2.000	0.500	.125
17196	2.000	1.000	.125
4018	2.500	1.500	.125
4017	3.000	1.000	.125
4802	3.000	1.500	.200
65439	4.000	1.500	.125

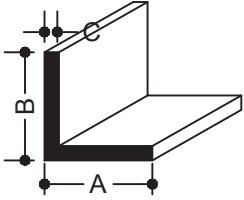

ÁNGULOS

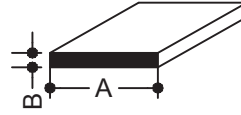

SOLERAS

CLAVE	MEDIDAS EN PULGADAS		
	A	B	C
74	0.375	0.375	.063
11031	0.500	0.500	.050
1301	0.500	0.500	.062
00009	0.500	0.500	.125
2	0.625	0.625	.063
662	0.750	0.750	.040
11033	0.750	0.750	.050
1303	0.750	0.750	.062
11	0.750	0.750	.125
11124	1.000	1.000	.040
1324	1.000	1.000	.050
1304	1.000	1.000	.062
1308	1.000	1.000	.125
25	1.000	1.000	.188
569	1.250	1.250	.063
13	1.250	1.250	.125
00026	1.250	1.250	.187
1320	1.500	1.500	.062
14	1.500	1.500	.125
1314	1.500	1.500	.187
372	1.500	1.500	.250
15	2.000	2.000	.125
330	2.000	2.000	.187
1318	2.000	2.000	.250
65496	2.500	2.500	.187
31	2.500	2.500	.250
29	3.000	3.000	.188
47	3.000	3.000	.250
667	4.000	4.000	.250

CLAVE	MEDIDAS EN PULGADAS	
	A	B
17102	0.375	.063
18040	0.375	.125
17978	0.500	.063
1203	0.500	.125
17578	0.500	.188
17582	0.500	.250
17572	0.625	.125
1201	0.750	.063
18028	0.750	.125
1211	0.750	.188
17584	0.750	.250
19095	0.750	.375
1202	1.000	.063
1205	1.000	.125
18091	1.000	.188
17980	1.000	.250
17593	1.000	.375
17090	1.000	.500
17574	1.250	.125
17580	1.250	.188
17594	1.250	.375
1207	1.500	.125
17083	1.500	.188
17981	1.500	.250
17595	1.500	.375
17597	1.500	.500
19094	1.750	.125
17084	1.750	.188
17576	2.000	.125
1216	2.000	.188
17708	2.000	.250
17088	2.000	.375
17091	2.000	.500
17086	2.500	.188
17588	2.500	.250
18041	3.000	.125
01218	3.000	.187
17589	3.000	.250
17089	3.000	.375
17092	3.000	.500
17687	4.000	.125
17591	4.000	.250
17628	4.000	.375
1241	4.000	.500
15009	5.000	.125
17087	5.000	.375
17592	6.000	.250

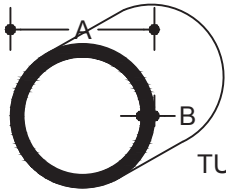

TUBO REDONDO

CLAVE	MEDIDAS EN PULGADAS	
	A	B
65524	0.375	.035
22004	0.375	.050
22023	0.500	.050
22015	0.625	.050
2108	0.750	.035
22505	1.000	.040
22356	1.250	.050
22117	1.250	.062
22197	1.500	.049
22196	2.000	.065
22326	2.500	.065

TUBO CUADRADO
ESQUINAS REDONDAS

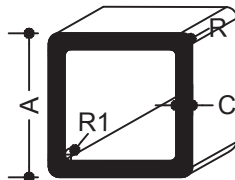































CLAVE	MEDIDAS EN PULGADAS			
	A	C	R	R1
22031	1.000	0.065	.156	.094
22034	1.500	0.065	.190	.125

CLAVE	FIGURA	SUP. ANOD. CM.	SUP. PUL. CM.	LARGO STD. M.	PIEZAS x ATADO	PÁGINA	CLAVE	FIGURA	SUP. ANOD. CM.	SUP. PUL. CM.	LARGO STD. M.	PIEZAS x ATADO	PÁGINA
00002	L	6.35	0	3.66	60	48	00622	L	11.43	11.43	3.66	16	47
00011	L	7.62	7.62	3.66	22	48	00662	L	7.62	7.62	6.10	3	48
00013	L	12.70	12.70	3.66	14	48	00667	L	40.64	40.64	3.66	2	48
00014	L	15.24	15.24	6.10	8	48	1201	—	4.13	4.13	3.66	80	48
00015	L	20.22	20.22	3.66	8	48	1202	—	5.40	5.40	3.66	40	48
00016	L	7.62	7.62	3.66	22	47	1203	—	3.17	3.17	3.66	62	48
00020	L	15.24	15.24	3.66	11	47	1205	—	5.71	5.71	3.66	30	48
00025	L	10.16	10.16	3.66	12	48	1207	—	8.19	8.19	3.66	20	48
00029	L	30.48	30.48	3.66	4	48	1211	—	4.76	4.76	3.66	26	48
00031	L	25.40	25.40	3.66	4	48	1216	—	11.11	11.11	6.10	8	39 48
00047	L	30.48	30.48	3.6	4	48	1241	—	22.86	22.86	3.66	4	48
00074	L	3.81	3.81	3.66	100	48	1301	L STOCK MEX	5.08	5.08	6.10	40	48
00330	L	20.32	20.32	6.10	3	48	1303	L STOCK MEX	7.62	7.62	3.66	32	48
00372	L	15.24	15.24	3.66	6	48	1304	L STOCK MEX	10.16	10.16	6.10	24	48
00569	L	12.7	6.35	3.66	25	48	1308	L	10.16	10.16	6.10	10	48































Perfiles de producción, pregunta por el mínimo de compra.

Los estatus de las claves pueden ir cambiando según demanda del mercado.

Vigente 2019.

CLAVE	FIGURA	SUP. ANOD. CM.	SUP. PUL. CM.	LARGO STD. M.	PIEZAS x ATADO	PÁGINA	CLAVE	FIGURA	SUP. ANOD. CM.	SUP. PUL. CM.	LARGO STD. M.	PIEZAS x ATADO	PÁGINA
1314		15.24	15.24	3.66 6.10	8 5	47	2358		30.48	30.48	6.10	2	47
1318		20.32	11.43	3.66	5	48	2362		10.16	10.16	6.10	16	47
1320		15.24	15.24	3.66 6.10	16 16	48	2363		15.24	15.24	6.10	8	47
1324		10.062	10.062	6.10	32	48	2364		17.76	17.76	6.10	9	47
1364		12.7	12.70	6.10	8	47	2365		40.64	40.64	6.10	1	47
1403		7.94	7.94	3.66	48	47	2369		30.48	30.48	6.10	4	47
1432		5.15	5.15	6	72	47	2500		7.62	7.62	6.10	12	47
1433		7.47	7.47	6	72	47	2513		19.05	19.05	6.10	6	47
1463		14.92	14.92	6.10	72	47	2514		12.70	12.70	6.10	8	47
1602		10.16	10.16	3.66	18	47	2515		11.43	11.43	6.10	12	47
1611		10.16	10.16	6.10	32	47	2516		20.32	20.32	6.10	4	47
1613		10.16	10.16	6.10	32	47	2520		29.21	29.21	6.10	3	47
2351		7.62	7.62	6.10	20	47	2521		15.24	15.24	6.10	8	47
2354		12.70	12.70	6.10	9	47	2522		24.13	24.13	6.10	3	47
2356		20.32	20.32	6.10	6	47	3316		8.00	5.18	6.10	24	32















Perfiles de producción, pregunta por el mínimo de compra.
 Los estatus de las claves pueden ir cambiando según demanda del mercado.
 Vigente 2019.















CLAVE	FIGURA	SUP. ANOD. CM.	SUP. PUL. CM.	LARGO STD. M.	PIEZAS x ATADO	PÁGINA	CLAVE	FIGURA	SUP. ANOD. CM.	SUP. PUL. CM.	LARGO STD. M.	PIEZAS x ATADO	PÁGINA
4005		9.52	5.10	3.66	18	47	6370		9.40	2.96	6.10	32	28
4017		24.765	24.765	3.66	8	47	6371	 STOCK MEX	8.50	2.62	6.10	24	29
4018		27.305	27.305	3.66	6	47	6775		29.20	10.60	6.10	8	33
4042		19.974	9.35	6.10	6	36	6901	 PRODUCCIÓN	27.30	20.00	6.10	4	29
4043	 STOCK MTY	26.449	12.12	6.10	4	36	7014		6.13	2.14	6.10	36	32
4081	 PRODUCCIÓN	33.4	17.13	6.10	2	36	7101		14.6	11.4	6.10	8	19
4105		6	1.62	6.10	40	29	7102		13.50	6.69	6.10	12	32
4114	 PRODUCCIÓN	39.19	17.85	6.10	4	36	7103		40.80	22.90	6.10	2	29
4127		10	6.76	6.10	24	32	7104	 STOCK MTY	21	10.48	6.40	8	21
4154		10	7	3.66	16	32	7105	 STOCK MTY	22	14	6.40	6	21
4688		5.40	5.40	3.66	70	47	7106	 STOCK MTY	27	13	6.40	10	21
5115	 STOCK MTY	8	1.65	6.10	28	29	7107	 STOCK MTY	20	7	6.40	12	21
5173		9	4	6.10	20	19	7108	 STOCK MTY	23.50	10	6.40	8	21
5472		25	8.26	6.10	10	43	7109	 STOCK MTY	51	7	6.40	4	21
5740	 PRODUCCIÓN	44.20	28.95	6.10	4	44	7110	 STOCK MTY	32.83	4.67	6.40	6	21

Perfiles de producción, pregunta por el mínimo de compra.

Los estatus de las claves pueden ir cambiando según demanda del mercado.

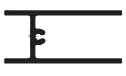
Vigente 2019.















CLAVE	FIGURA	SUP. ANOD. CM.	SUP. PUL. CM.	LARGO STD. M.	PIEZAS x ATADO	PÁGINA
7112	 STOCK MTY	20.30	14	6.40	8	21
7158	 PRODUCCIÓN	74.77	30.88	6.10	2	12
7333		8.06	3.10	6.10	40	19
7671		28.31	7.991	6.10	8	37
7792		14.50	0	6.10	16	6
7818		7.60	3.80	6.10	20	15
7828		10.50	5.30	6.10	16	18
7851		41	15	6.10	4	28
7949		12.89	5.90	6.10	16	31
7950	 STOCK MEX STOCK MTY	15.421	8	5.70	16	31
8184	 STOCK MTY	14.25	4.20	6.10	12	10
8320		18.32	8.08	6.10	8	15
8328		40.80	18.20	6.10	1	37
8524		24.77	10.20	6.10	8	33
9078	 PRODUCCIÓN	10.38	0	6.10	28	4





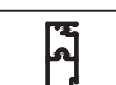









CLAVE	FIGURA	SUP. ANOD. CM.	SUP. PUL. CM.	LARGO STD. M.	PIEZAS x ATADO	PÁGINA
9086		30	8.30	6.10	8	6
9088		11.50	3.5	6.10	32	6
9112		13.23	4.80	6.10	12	7 9 24
9236	 STOCK MEX	23.012	15.474	6.10	8	25
9356		8.01	3.30	6.10	24	4
9525		15.10	8.10	6.10	16	30
9756		13	10.30	6.10	12	30
9947		37	15.20	6.10	8	30
9956		19.10	8.206	6.10	12	14
9958		19.70	12.00	6.10	10	18
9959		33.00	15.80	6.10	6	18
9960	 STOCK MTY	28.882	12	6.10	8	18
9963	 STOCK MTY	22.26	15.1	6.10	8	18
9964	 STOCK MTY	23	21	6.10	6	18
9965		16.40	8.60	6.10	16	18

Perfiles de producción, pregunta por el mínimo de compra.

Los estatus de las claves pueden ir cambiando según demanda del mercado.

Vigente 2019.

CLAVE	FIGURA	SUP. ANOD. CM.	SUP. PUL. CM.	LARGO STD. M.	PIEZAS x ATADO	PÁGINA
9966		10.071	3.57	6.10	20	19
10087		23.80	11.814	6.10	8	40
10088	 PRODUCCIÓN	19	19	6.10	12	40
10103		18	11.80	6.10	12	30
10197		14.88	3.17	5.70	20	30
10198		16.94	3.17	6.10	16	19
10220		7.80	2.37	5.70	30	19
10235		39	12.70	6.10	8	9
10236		35.30	7.90	6.10	6	9
10237		22.70	6	6.10	16	9
10266		21.30	0	6.10	12	8 10
10358		17.50	8.60	6.10	12	19
10465		50.20	15.03	6.10	4	24
10466		28.17	12.88	6.10	8	24
10467		47	11.20	6.10	4	24

CLAVE	FIGURA	SUP. ANOD. CM.	SUP. PUL. CM.	LARGO STD. M.	PIEZAS x ATADO	PÁGINA
10554	 STOCK MEX	7.08	3.45	6.10	32	24
10568	 STOCK MEX STOCK MTY	26.03	6.30	6.40	12	20
10570	 STOCK MEX STOCK MTY	25.57	16.71	6.40	12	20
10571	 STOCK MEX STOCK MTY	18.60	6.73	6.40	12	20
10574	 STOCK MEX STOCK MTY	8.03	3	6.40	36	20
10575	 STOCK MEX STOCK MTY	9.67	3.03	6.40	24	20
10581		55.57	15.39	6.10	2	43
10697	 PRODUCCIÓN	48.30	20.90	6.10	4	24
10921		5.60	2.55	6.10	40	29
11005	 PRODUCCIÓN	33.10	23.70	6.10	2	43
11031	 STOCK MEX PRODUCCIÓN	5.08	5.08	6.10	40	48
11032		7.15	1.86	6.10	48	25 29
11033		7.62	7.62	6.10	32	48
11035		11.30	3.37	6.10	12	31
11044		18.27	8.11	6.10	12	14

Perfiles de producción, pregunta por el mínimo de compra.

Los estatus de las claves pueden ir cambiando según demanda del mercado.

Vigente 2019.































ÍNDICE GENERAL









CLAVE	FIGURA	SUP. ANOD. CM.	SUP. PUL. CM.	LARGO STD. M.	PIEZAS x ATADO	PÁGINA
11046		14.194	10.463	6.10	12	31
11093		17.76	17.76	6.10	9	47
11096	 PRODUCCIÓN STOCK MTY	9.60	3.45	6.10	32	13
11099		19.05	19.05	6.10	6	47
11122		24.13	24.13	6.10	3	47
11124		10.16	10.16	6.10	32	48
11131		48.804	48.804	6.10	4	41
11154		12.70	12.70	6.10	9	47
11156		20.32	20.32	6.10	6	47
11161		10.16	10.16	6.10	16	47
11162		34.956	34.956	6.10	4	41
11163		17.62	8.927	6.10	12	43
11173		15.41	11.958	6.10	12	31
11174		34.90	15.20	6.10	8	31
11176	 STOCK MEX	29.50	12.50	6.10	8	31

CLAVE	FIGURA	SUP. ANOD. CM.	SUP. PUL. CM.	LARGO STD. M.	PIEZAS x ATADO	PÁGINA
11203		13.20	5.82	6.10	12	13 15
11286		17.97	0	6.10	8	43
11338		73.00	28.50	6.10	2	46
11386		14.90	4.01	5.70	20	31
11387		17.16	4.011	6.10	16	31
11417		45.46	14.78	6.10	2	43
11558		32.847	23.09	6.10	2	38
11599		17.20	9.65	6.10	10	40
11670		26.52	10.203	6.10	8	33
11672	 PRODUCCIÓN STOCK MTY	34.75	15.13	6.10	8	34
11763	 STOCK MEX STOCK MTY	5.55	0	6.10	40	13
11835		36.69	7.349	6.10	12	13
11836		14.24	5.08	6.10	16	13
11837		18.659	8.1	6.10	12	13
11838		17.5	3.98	6.10	12	13

Perfiles de producción, pregunta por el mínimo de compra.
 Los estatus de las claves pueden ir cambiando según demanda del mercado.
 Vigente 2019.

CLAVE	FIGURA	SUP. ANOD. CM.	SUP. PUL. CM.	LARGO STD. M.	PIEZAS x ATADO	PÁGINA	CLAVE	FIGURA	SUP. ANOD. CM.	SUP. PUL. CM.	LARGO STD. M.	PIEZAS x ATADO	PÁGINA
12115		37.8	14.70	6.10	2	35	15314	 PRODUCCIÓN	7.14	2.30	6.10	56	13
12208		31.75	31.75	6.10	2	45	17003		10.69	5.66	3.66	18	47
12428	 PRODUCCIÓN	9.99	8.18	6.10	22	37	17083		8.57	8.57	3.66	12	48
12797	 PRODUCCIÓN	36.95	11.90	6.10	8	20	17084		9.84	9.84	3.66	12	48
13562		41.66	18.61	6.10	6	34	17086		13.65	13.65	3.66	8	48
13563		14.80	7.53	6.10	6	30	17088		12.065	12.065	3.66	5	48
14286		21.28	7.08	6.10	8	14	17089		17.145	17.145	3.66	4	48
14668	 PRODUCCIÓN STOCK MEX	73.03	24.52	6.10	1	44	17090		7.62	7.62	3.66	8	48
14669	 PRODUCCIÓN STOCK MEX	63.58	24.52	6.10	2	44	17091		12.70	12.70	3.66	4	48
14729		29.21	29.21	6.10	3	47	17092		17.78	17.78	3.66	2	48
15309		28.663	6.46	6.10	12	13	17102		2.22	0	3.66	180	48
15310		18.471	4.05	6.10	20	13	17196		19.685	19.685	3.66	8	48
15311		18.431	7.81	6.10	22	13	17231		10.16	10.16	3.66	17	47
15312		13.428	8.88	6.10	30	13	17256		7.62	7.62	3.66	32	47
15313	 PRODUCCIÓN	15.383	6.10	6.10	26	13	17572		3.745	3.745	3.66	50	48















Perfiles de producción, pregunta por el mínimo de compra.
 Los estatus de las claves pueden ir cambiando según demanda del mercado.
 Vigente 2019.















CLAVE	FIGURA	SUP. ANOD. CM.	SUP. PUL. CM.	LARGO STD. M.	PIEZAS x ATADO	PÁGINA	CLAVE	FIGURA	SUP. ANOD. CM.	SUP. PUL. CM.	LARGO STD. M.	PIEZAS x ATADO	PÁGINA
17574	—	6.92	6.92	3.66	24	48	17708	—	11.43	11.43	3.66	8	48
17576	—	10.73	10.73	3.66	16	48	17977		14.6	7.62	3.66	12	47
17578	—	3.49	3.49	3.66	42	48	17978	—	2.79	2.79	3.66	125	48
17580	—	7.30	7.30	3.66	17	48	17980	—	6.35	6.35	3.66	16	48
17582	—	3.81	3.81	3.66	32	48	17981	—	8.89	8.89	3.66	10	48
17584	—	5.08	5.08	3.66	22	48	18028	—	4.38	4.38	3.66	42	48
17588	—	13.97	13.97	3.66	6	48	18040	—	2.475	2.475	3.66	82	48
17589	—	16.51	16.51	3.66	5	48	18041	—	15.81	15.81	3.66	10	48
17591	—	21.59	21.59	3.66	4	48	18081		7.30	7.30	3.66	50	47
17592	—	31.75	31.75	3.66	3	48	18091	—	6.03	6.03	3.66	12	48
17593	—	6.985	6.985	3.66	12	48	18270	 STOCK MTY	39.92	11.21	6.10	4	10
17594	—	8.255	8.255	3.66	8	48	18490		12.06	12.06	3.66	14	47
17595	—	9.525	9.525	3.66	8	48	19095	—	5.715	5.715	3.66	14	48
17597	—	10.16	10.16	3.66	5	48	19272	 STOCK MTY	20.50	13.38	6.40	15	20
17628	—	22.225	22.225	3.66	3.6	48	19613		24.13	24.13	6.10	4	47

Perfiles de producción, pregunta por el mínimo de compra.

Los estatus de las claves pueden ir cambiando según demanda del mercado.

Vigente 2019.

CLAVE	FIGURA	SUP. ANOD. CM.	SUP. PUL. CM.	LARGO STD. M.	PIEZAS x ATADO	PÁGINA
20569	 STOCK MTY	27.84	6.72	6.40	8	20
20572		9.98	1	6.10	24	20
22004		2.99	2.99	6.10	46	48
22015		4.987	4.987	3.66 6.10	50 16	48
22017		29.21	29.21	6.10	2	47
22023		3.99	3.99	3.66 6.10	55 33	48
22026		24.13	24.13	6.10	3	47
22031		8.43	8.43	6.10	6	48
22034		14.41	14.41	6.10	6	48
22036		7.62	7.62	6.10	16	47
22049		7.62	7.62	6.10	14	47
22107		29.14	29.14	6.10	2	47
22117		9.97	9.97	6.10	10	48
22196		15.96	15.96	3.66 6.10	8 6	48
22197		11.97	11.97	6.10	9	48

CLAVE	FIGURA	SUP. ANOD. CM.	SUP. PUL. CM.	LARGO STD. M.	PIEZAS x ATADO	PÁGINA
22242		20.32	20.32	6.10	6	47
22268		15.24	15.24	6.10	4	47
22273		25.40	25.40	6.10	2	47
22326		19.95	19.95	3.66	4	48
22356		9.97	9.97	6.10	12	48
22505		7.98	7.98	3.66 6.10	24 12	48
23979	 PRODUCCIÓN	42.9	29.01	6.10	2	39
24051		11.65	4.74	6.10	16	6
24055		19.806	8.55	6.10	10	11
26606		18.48	6.40	6.10	12	12
26609		30.05	7.44	6.10	8	11
27111	 STOCK MTY	37.86	9.098	6.40	6	21
27316		17.2	7.28	6.10	12	7
27525		10.813	1.20	6.10	16	15
27819		43.38	8.75	6.10	6	14

Perfiles de producción, pregunta por el mínimo de compra.

Los estatus de las claves pueden ir cambiando según demanda del mercado.































Vigente 2019.

CLAVE	FIGURA	SUP. ANOD. CM.	SUP. PUL. CM.	LARGO STD. M.	PIEZAS x ATADO	PÁGINA	CLAVE	FIGURA	SUP. ANOD. CM.	SUP. PUL. CM.	LARGO STD. M.	PIEZAS x ATADO	PÁGINA
27862		49.018	7.36	6.10	4	16	35844		25.697	12.91	6.10	8	29
28009	 STOCK MEX	62.56	26.596	6.10	1	39	36370		10.40	2.90	6.10	32	4 28
28183	 STOCK MTY	33.152	6.74	6.10	8	10	37825		27.75	15.76	6.10	8	14
28586		37.303	14.04	6.10	4	6	38370		26.74	3.04	6.10	8	14
28681		17.35	2.13	6.10	12	18	39073		25.95	8.20	6.10	12	4
28936		24.45	6.24	6.10	6	23	39074		22.20	5.32	6.10	12	4
28937		31.249	5.80	6.10	6	23	39075		11.09	2.39	6.10	30	4
28939		15.38	5.10	6.10	12	23	39084		28.91	6.885	6.10	8	6
29076		21.133	9.165	6.10	12	4	39088	 STOCK MTY	10.442	3.517	6.10	32	6
29117		55.753	19.46	6.10	4	11	39115	 STOCK MTY	54.639	21.87	6.10	4	8
29118		48.178	13.159	6.10	4	12	39136		39.041	10.82	6.10	6	7
29119		45.63	20.61	6.10	4	11	39272		33.199	9.416	6.10	6	17
29183		19.67	8.60	6.10	6	28	39954		17.897	8.418	6.10	8	15
29207		22.782	10.562	6.10	6	28	40156		11.11	11.11	6.10	20	47
33087		18.79	4.24	6.10	12	25	50170		5.08	5.08	6.10	30	47

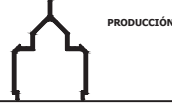













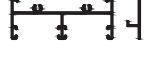



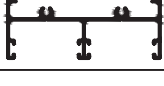

Perfiles de producción, pregunta por el mínimo de compra.

Los estatus de las claves pueden ir cambiando según demanda del mercado.

















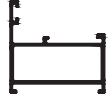

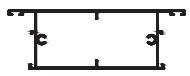
Vigente 2019.

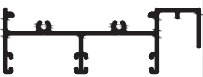
CLAVE	FIGURA	SUP. ANOD. CM.	SUP. PUL. CM.	LARGO STD. M.	PIEZAS x ATADO	PÁGINA	CLAVE	FIGURA	SUP. ANOD. CM.	SUP. PUL. CM.	LARGO STD. M.	PIEZAS x ATADO	PÁGINA
51945		40.88	29.96	6.10	1	38	63463		32.88	25.35	6.10	2	45
52500		7.62	7.62	6.10	20	47	63727		13.34	3.46	6.10	16	15
53358		15.79	6.75	6.10	12	32	63728		17.96	7.01	6.10	6	15
53883		27.32	22.57	6.10	3	38	63862		28.15	13.59	6.10	12	12
53896		22.219	17.42	6.10	4	38	64498		35.18	7.23	6.10	1	45
59187		33.425	16.183	6.10	4	28	65439		34.93	0	3.66	4	47
59204		21.54	16.913	4.60 6.10	6 6	28	65498		8.26	4.45	3.66	24	48
62488		10.16	10.16	6.10	16	47	65321		20.32	20.32	6.10	6	47
62489		15.24	15.24	6.10	9	47	65524		2.992	0	6.10	50	48
62509		22.86	22.86	6.10	3	47	65844		18.535	9.25	6.10	12	28
62515		11.43	11.43	6.10	12	47	66053		24.35	10.81	6.10	8	40
62521		15.24	15.24	6.10	8	47	66533		21.293	9.47	6.10	12	19
62899		40.179	7.17	6.10	3	45	66534		17.001	9.354	4.60	8	19
63299		17.61	17.61	6.10	13	40	66617		31.77	28.76	6.10	6	35
63329		14.846	2.90	6.10	20	32	67013		9.66	2	6.10	36	32

Perfiles de producción, pregunta por el mínimo de compra.
 Los estatus de las claves pueden ir cambiando según demanda del mercado.
 Vigente 2019.

CLAVE	FIGURA	SUP. ANOD. CM.	SUP. PUL. CM.	LARGO STD. M.	PIEZAS x ATADO	PÁGINA	CLAVE	FIGURA	SUP. ANOD. CM.	SUP. PUL. CM.	LARGO STD. M.	PIEZAS x ATADO	PÁGINA
67166	 PRODUCCIÓN	29.21	22.72	6.10	6	35	67848		29.311	16.182	4.60	8	17
67315		25.779	6.17	6.10	8	7	67850		27.25	13.93	6.10	6	17
67362		31.61	31.61	6.10	3	42	67862		56.03	6.87	6.10	4	17
67363		21.23	21.23	6.10	4	42	68327		39.90	18.28	6.10	1	37
67518		37.168	8.07	6.10	8	14	68370		26.74	3.04	6.10	8	14
67819		49.52	8.64	6.10	6	14	68380	 STOCK MEX	43.594	17.19	6.10	6	34
67821		14.10	10.76	4.60	12	15	68550	 STOCK MEX	20.58	9.55	6.10	12	25
67822		22.22	15.92	6.10	8	15	68591		26.861	11.381	6.10	8	6
67826		43.24	23.11	6.10	6	16	69082		27.448	9.86	6.10	8	18 26
67835		35.059	13.20	6.10	8	25 16	69083		32.69	0	6.10	8	6
67836		24.386	8.619	6.10	8	25 16	69085		15.7	3.62	6.10	16	6
67842		34.343	17.17	6.10	4	25 16	69105		41.458	12.1	6.10	4	7
67843		26.181	10.87	6.10	8	17	69114		37.57	16.72	6.10	4	7
67844		24.798	11.31	6.10	8	17	69135		46.023	15.365	6.10	4	7
67847		22.031	14.774	4.60	8	17	69272		32.562	11.12	6.10	6	16

Perfiles de producción, pregunta por el mínimo de compra.
 Los estatus de las claves pueden ir cambiando según demanda del mercado.
 Vigente 2019.

CLAVE	FIGURA	SUP. ANOD. CM.	SUP. PUL. CM.	LARGO STD. M.	PIEZAS x ATADO	PÁGINA	CLAVE	FIGURA	SUP. ANOD. CM.	SUP. PUL. CM.	LARGO STD. M.	PIEZAS x ATADO	PÁGINA
69366		31.696	12.322	6.10	6	39	69957		27.682	16.461	6.10	8	16
69768		23.721	8.512	6.10	12	16	70164		23.609	11.518	6.10	6	26
69776		58.709	25.68	6.10	1	39	70165		29.477	14.356	6.10	2	26
69877		20.297	6.725	6.10	8	5	70166		29.477	14.432	6.10	2	26
69878		24.96	8.454	6.10	6	22	70647		38.24	22.611	6.10	2	27
69881		24.96	8.454	6.10	6	22	77862		49.65	9.80	6.10	6	16
69885		38.51	24.98	6.10	2	26	81581		32.485	13.08	6.10	8	33
69887		11.389	2.154	6.10	30	5 22 27							
69888		12.005	2.481	6.10	30	5 22 27							
69889		5.347	2.537	6.10	30	22							
69890		12.768	3.752	6.10	30	5 22 27							
69891		11.923	3.425	6.10	30	5 22 27							
69955		21.557	10.985	4.60	12	15							

Perfiles de producción, pregunta por el mínimo de compra.

Los estatus de las claves pueden ir cambiando según demanda del mercado.

Agradeceremos sus comentarios sobre este catálogo.

Atención: Departamento de asesoría técnica Grupo Cuprum.

Contacto: vozdelcliente@cuprum.com



PLANTA MONTERREY

AV. DIEGO DIAZ DE BERLANGA #132,
COL. EL NOGALAR, SAN NICOLAS
DE LOS GARZA, NL. C.P. 66480

PLANTA GUADALAJARA

ANTIGUA CARRETERA A CHAPALA
#3345, ALAMO INDUSTRIAL,
GUADALAJARA, JALISCO

PLANTA MÉXICO

AV. LA PRESA #290, COL. SAN
JUAN IXHUATEPEC TLALNEPANTLA,
EDO. DE MÉXICO CP 54180