

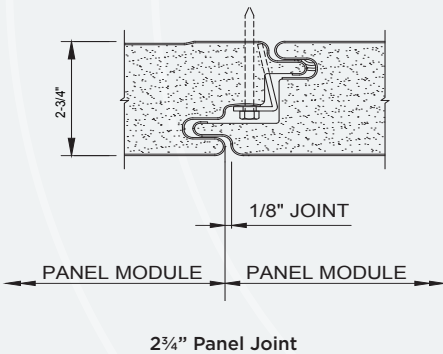

DESCRIPTION

Versawall V+ Insulated Metal Panels create an attractive and energy efficient wall where vertical applications are desired. Available in Flat, Striated and Planked profiles and up to 4" thickness to create a high-performing building envelope. Ideal for government facilities, schools or arenas. Versawall V+ panels are remarkably strong and provide outstanding protection with lengths to 37'.

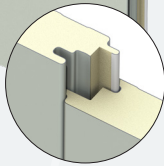
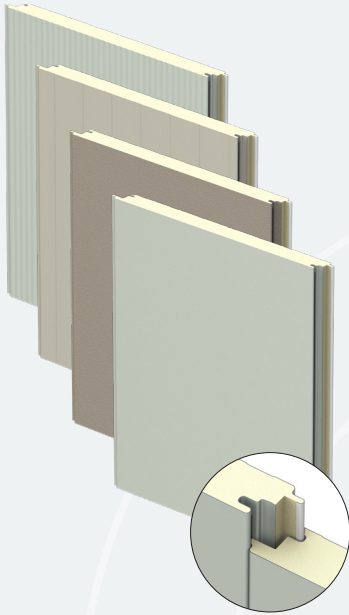

GENERAL DESIGN OPTIONS

VERSAWALL V+			
PANEL THICKNESS	2" [51mm], 2¾" [70mm], 4" [102mm]		
PANEL MODULE	30" [762mm], 36" [914mm]		
PANEL CORE	Foamed-in-placed polyisocyanurate (PIR)		
THERMAL VALUES *		U Value BTU/hr•ft²•°F	R Value hr•ft²•°F/BTU
	2"	0.063	16.7
	2¾"	0.046	23.0
	4"	0.034	33.5
END JOINT	Stack Joint		
SIDE LAP	Double tongue and groove		
SIDE LAP REVEAL	1/8"		
STANDARD PANEL LENGTHS	Embossed	Flat - 6' [1.8m] - 37' [11.3m]	
		Max. 21' [6.4m] - Dark Colors Only	
STANDARD PANEL LENGTHS	Smooth	Max. 37' [11.3m] - Light Colors Only	
		Flat - 6' [1.8m] - 20' [6.1m]	
		Planked - 6' [1.8m] - 20' [6.1m] Striated - 6' [1.8m] - 20' [6.1m]	
STANDARD EXTERIOR FACE & GAUGE	22 ga. Flat, Smooth		
OPTIONAL EXTERIOR FACE & GAUGE	20, 22 ga. Smooth, Flat, Striated or Planked 20, 22 ga. Embossed, Flat		
STANDARD INTERIOR LINER & GAUGE	26 ga. Planked, Embossed*		
OPTIONAL INTERIOR LINER & GAUGE	20, 22, 24 ga. Planked, Embossed		
WEIGHTS	2" = 2.67 - 3.81 lbs./sq. ft.		
	2¾" = 2.85 - 4.00 lbs./sq. ft.		
	4" = 3.17 - 4.31 lbs./sq. ft.		

* 2" smooth exterior panels require 22 ga. non-planked/flat liner
+ U-Factor & R-Value per ASTM C1363/simulation & ASTM C518 and based on a mean temperature of 35° F; Standard I-P unit convention shown.

VERSAWALL V+ DESIGN FEATURES & BENEFITS

- Lightweight vertical panels lower installation costs
- Increased span capability reduces support steel requirements
- Thermal break between face and liner saves energy
- Factory-applied panel joint sealant, together with field-applied sealant, create an air and vapor barrier that provides outstanding weather resistance
- Versawall can be used for interior partitions
- Available with factory-formed sheet metal flashing or extruded aluminum trim



VERSAWALL V+ TESTING

TEST	TEST METHOD	TEST TITLE	RESULTS		
FIRE US	ASTM E84	Surface Burning Characteristics of Building Materials	Meet requirements of Class A per IBC Section 803.1.2 (FS < 25, SD < 450)		
	ASTM E119/UL 263	Fire Tests of Building Construction and Materials	See UL Fire Resistance Directory for tested assemblies		
	NFPA 259	Standard Test Method for Potential Heat of Building Materials	Meets requirements of IBC 2603.5.3		
	NFPA 285	Evaluation of Fire Propagation Characteristics of Exterior Non-Load Bearing Wall Assemblies	Assembly meets requirements of IBC Section 2603.5.5; Contact CENTRIA for assistance		
	NFPA 286	Standard Methods of Fire Tests for Evaluating Contribution of Wall and Ceiling Interior Finish to Room Fire Growth	Meets requirements of IBC Section 803		
	FM 4880	Class 1 Fire Rating of Insulated Wall, Ceiling and Roof Panels	See FM Approval Listings		
FIRE CANADA	CAN/ULC S101	Standard Methods of Fire Endurance Tests of Building Construction and Materials	Meets requirements of Article 3.1.5.7 (2b)		
	CAN/ULC S102	Standard Method of Test for Surface Burning Characteristics of Building Materials and Assemblies	Flame spread rating = 25 Smoke developed classification = 240		
	CAN/ULC S134	Standard Method of Fire Test of Exterior Wall Assemblies	Meets requirements of Article 3.1.5.5 (1b)		
STRUCTURAL	ASTM E72	Standard Test Methods of Conducting Strength Tests of Panels for Building Construction	See Span Tables		
	FM 4881	Class 1 Exterior Wall Structural Performance	See FM Approval Listings (SH Rating)		
THERMAL PERFORMANCE	ASTM C518	Steady-State Thermal Transmission Properties by Means of the Heat-Flow Meter Apparatus*		U Factor BTU/hr·ft²·°F	R Value hr·ft²·°F/BTU
	ASTM C1363	Thermal Performance of Building Materials and Envelope Assemblies*	2"	0.063	16.7
			2 3/4"	0.046	23.0
4"	0.034	33.5			
AIR INFILTRATION	ASTM E283	Rate of Air Leakage Through Exterior Windows, Curtain Walls, and Doors	< 0.01 cfm/ft² air infiltration rate at static pressure differential of 6.24 psf		
WATER INFILTRATION	ASTM E331	Water Penetration of Exterior Windows, Skylights, Doors and Curtain Walls by Uniform Static Air Pressure Difference	No uncontrolled water penetration at static pressure differential of 6.24 psf for 2 hours (IBC Section 1402) and 15 psf for 15 minutes		
	AAMA 501.1	Standard Test Method for Water Penetration of Exterior Walls Using Dynamic Pressure	No leakage at a dynamic pressure of 15 psf for 15 minutes		
ACOUSTICAL	ASTM E90 & ASTM E 413	Airborne Sound Transmission Loss of Building Partitions Classification for Rating Sound Insulation	Assemblies available ranging from STC=23 to 48, SAA = 0.84, & NRC= 0.84 to 0.90; Contact CENTRIA for assistance		
	ASTM C423 & ASTM E795	Sound Absorption and Sound Absorption Coefficients by the Reverberation Room Method Practices for Mounting Test Specimens During Sound Absorption Tests	Assemblies available ranging from STC=23 to 48, SAA = 0.84, & NRC= 0.84 to 0.90; Contact CENTRIA for assistance		
SPECIAL APPROVALS	Florida Product Approval HVHZ	Product Approval for HVHZ areas in the State of Florida	(Approval No. FL29083)		
	Florida Product Approval non-HVHZ	Product Approval for non-HVHZ areas in the State of Florida	(Approval No. FL3155)		
	LA City Research Report (LARR)		(LARR Report No. 25578)		

* U-Factor & R-Value per ASTM C1363/simulation & ASTM C518 and based on a mean temperature of 35° F; Standard I-P unit convention shown.

NOTES

- For information on special applications, contact your local CENTRIA Sales Representative.
- Maximum support spacing and panel length may be limited for medium and dark colors due to thermal stress, consult CENTRIA.
- Length limitations may vary based on color. Contact CENTRIA for details.